

## Training Program DC Products - Clutches and Brakes

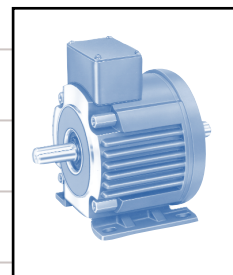
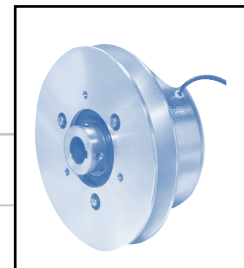
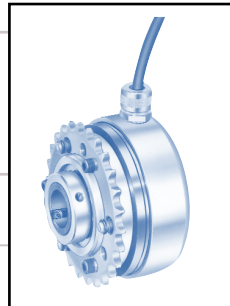

### Table of Contents

Section	Title	Page
	Introduction . . . . .	1
1	Fundamental Concepts . . . . .	2
2	Purpose of Clutches and Brakes . . . . .	3-4
3	Types of Clutches and Brakes . . . . .	5-7
4	Principles of Friction Braking and Clutching . . . . .	8-9
5	Principles of Electrically Actuated Friction Clutches and Brakes . . . . .	10-13
6	Basic Rectifier/Power Supply Controls . . . . .	14-15
7	Two Step Selection Procedure . . . . .	16-17
8	Engineering Fundamentals and Detailed Selection Procedure . . . . .	18-26
	Multiplication of Torque . . . . .	21
	Inertia . . . . .	21-22
	Calculation of Inertia . . . . .	22-23
	Reflected Inertia . . . . .	23-25
	Dynamic Torque . . . . .	25
	Thermal Capacity . . . . .	25-26
9	Summary . . . . .	27
10	Typical Stearns DC Product Applications . . . . .	28
11	Appendix . . . . .	29-31
12	Other Products . . . . .	32-34

## Introduction

A power transmission system converts energy into useful work.

In a typical system, an electric motor is used to convert electrical energy into rotating mechanical energy. Mechanical energy can be transmitted by a system of mechanical components to perform some useful function or work.

This system, composed of mechanical components may include one or more of the following:

- Shafts
- Bearings
- Cams
- Levers
- Shaft couplings
- Pulleys and belts
- Clutches and brakes
- Etc.

Our intent in this program or guide is to discuss clutches and brakes which, when used in a power transmission system, can control the flow or transmission of mechanical energy.

There are many different types of clutches and brakes. The Stearns products discussed in this guide will narrow down to electromechanical clutches and brakes which fall under our general heading of DC products.

Catalog Data, Installation, and Parts Sheets for these products can be found at [www.rexnord.com/brakes.html](http://www.rexnord.com/brakes.html).

# 1. Fundamental Concepts

We say that objects possess energy when they can do work. And that power is the rate at which work is performed or that energy is used. In the English or US customary engineering system, the units of power are the horsepower (hp) and the kilowatt (kw).

A)  $Power = \frac{work}{time}$

Work is defined as the product of an incremental displacement and of the force vector in the direction of the displacement. When a force of one pound acts through a distance of one foot, than 1 ft-lb of work is done.

B)  $Work = distance \times force$   
*Example units* = foot-pound  
 = inch-ounce  
 = inch-pound

Power is defined as:

C)  $Power = \frac{distance \times force}{time}$

The next concept is that of torque. If a force is applied to a lever which is free to pivot around one fixed point, the lever, unless restrained, will rotate about the pivot point. The motive action for this rotation, termed torque, is defined as the product of force and the perpendicular distance from the pivot to the force vector.

D)  $Torque = force \times distance$   
*Example units* = pound-foot  
 = ounce-inch  
 = pound-inch

Unlike work, which only occurs during movement, torque may exist even though no movement or rotation occurs.

**Example:**

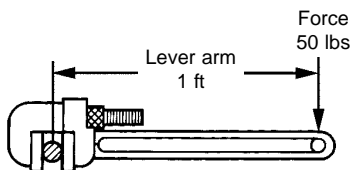

$Torque = 50 \text{ lbs} \times 1 \text{ ft}$   
 $Torque = 50 \text{ lb-ft}$

Note: The term ft-lb is the unit of measurement for work. Because most power transmission is based upon rotating elements, torque is important as a measurement of the effort required to produce work.

Friction is another concept that needs review. Frictional force can be defined as the resistance force that two objects surfaces exert on each other under sliding or conditions that they would tend to slide over each other.

E)  $Frictional \text{ force} = \mu \times \text{contact force}$   
 (frictional resistance) = (coefficient of friction  
 x normal force)

The last fundamental concept to be covered is inertia. Inertia is a measure of a body's resistance to changes in velocity, whether the body is at rest or moving at some constant velocity.

The moment of inertia ( $Wk^2$ ) of a rotating body is the product of the weight of the object and the square of the radius of gyration. The radius of gyration is a measure of how the mass of the object is distributed about the axis of rotation. Because of mass distribution, a small diameter cylindrical part has a much smaller inertia than a larger diameter cylindrical part, when rotating about the diameters centerline.

We normally associate the term - flywheel, when talking about inertia of rotating components.

**Example: Hollow cylinder**

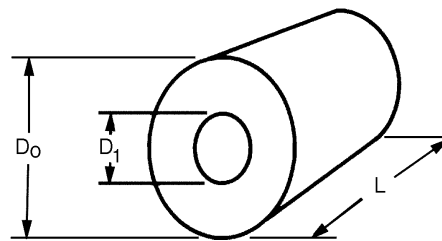

$L$  = Cylinder Length

$Wk^2 = .000681 \rho L (D_o^4 - D_i^4)$

$Wk^2$  = Inertia of cylinder, lb-ft<sup>2</sup>

$D$  = Diameter, inches

$\rho$  = Density, lb/in<sup>3</sup>

Common material densities: Steel = 0.2816 lb/in<sup>3</sup>

Aluminum = 0.0977 lb/in<sup>3</sup>

To calculate the inertia of a pulley or a gear, divide the object into elemental pieces, perform calculations for each separate piece and then add these together for a total inertia.

## 2. Purpose of Clutches and Brakes

A clutch or brake in a power transmission system functions as a door or gate. These components direct the flow of rotational energy to start or/and stop work. Just as a light switch is used to turn an electric light on and off; clutches and brakes are used to turn power on and off to a load.

The following examples and diagrams illustrate where clutches and brakes can be used and why these components are advantageous.

### System without clutches or brakes

The first example is a simple power transmission system consisting of a motor coupled to a reducer, which in turn is coupled to a load (Figure 2-1).

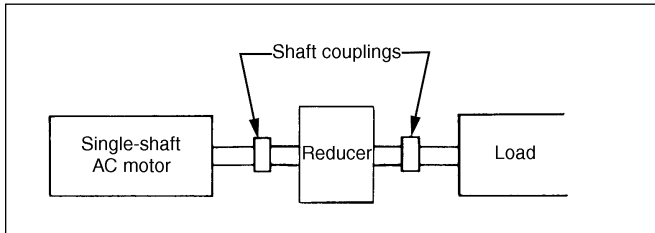

Figure 2-1: Basic power transmission system

The only way to control motion of the load in this example is to turn the motor on and off. The chief advantage of this type of power transmission system is very low initial cost. However, there are many disadvantages. When a motor is turned on it must accelerate not only the inertia of the load but also its own inertia. Therefore, there is a definite lag between the time the motor is turned on and the time at which the load reaches rated speed. There is also a lag between the time the motor is turned off and the time the load stops rotating, again due to the inertia of the load and motor. Another disadvantage of this type of system is the limited number of start-stop cycles it is capable of making. Rapid cycling of a motor causes excessive heat to build up in the motor windings, resulting in a shorter life.

### System using a clutch coupling

The second example system consists of a motor, clutch-coupling, reducer, and load (Figure 2-2). As its name implies, clutch-coupling, it is used to couple two shafts; for instance, the motor shaft to the reducer shaft. The clutch coupling can be used only to connect two in-line shafts and is often used to replace a mechanical type of coupling. The drive half of the clutch coupling is usually mounted to the motor output shaft. The driven half is usually mounted to the load or reducer input shaft.

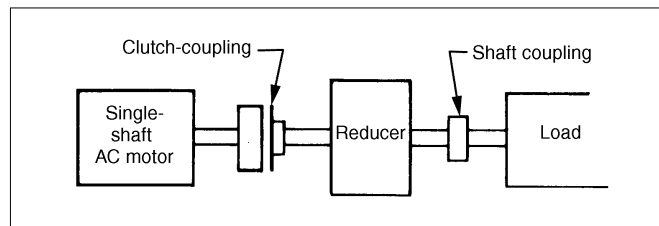

Figure 2-2: In-line system with clutch

In the bearing mounted clutch coupling configuration, the clutch drive half is mounted directly to the shaft and supported by the shaft. The stationary field magnetic coil and body is supported and isolated from shaft rotation by a bearing. The magnet body need only be restrained from rotating about the shaft. In this system, the clutch coupling is used to start the load after the motor has accelerated to rated speed under no load conditions. The load can then be coupled to the motor by engaging the clutch. The motor would run at all times. Therefore, heat build up due to high motor starting currents would be minimized. Furthermore, the inertia of the motor would act as a fly-wheel, and

function as part of the power to accelerate the load. The primary advantage of this system is very little wear and tear on the motor. A disadvantage lies in the fact that there is no braking, and there will be a lag between the time the clutch is disengaged and the load decelerates to zero. An advantage of this system is the fact that the control functions are very simple. A low power relay can be used to switch the clutch on and off.

### System using a clutch

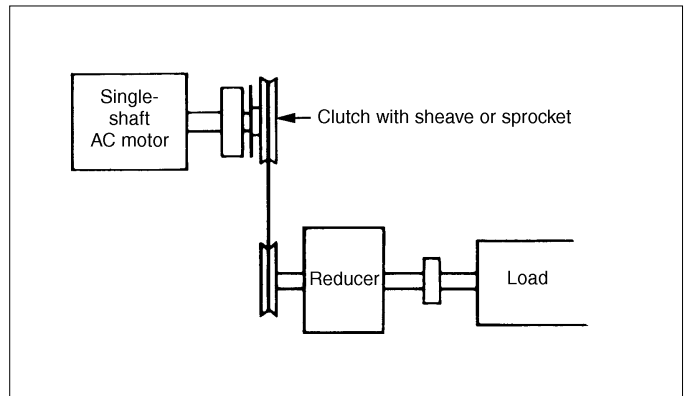

Figure 2-3: Parallel-shaft system with clutch

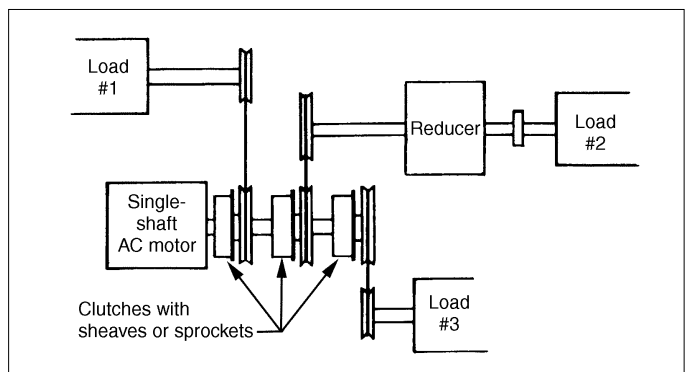

Figure 2-4: Parallel-shaft system with multiple clutches

alignment. Many of these one piece units are available with integral sheaves, sprockets, or timing belt pulleys. This type of system has a rather unique feature. Any number of clutches can be mounted on a single shaft or jack shaft coupled to the motor shaft (Figure 2-4). Each clutch can drive an additional shaft, thereby permitting one motor to act as a power source for several power transmission systems.

**System using a brake**

The next power transmission type of unit is the brake. In this system (Figure 2-5) we change from a starting motion to a stopping motion. The clutch has been replaced with a brake. Using this product stopping the load is virtually instantaneous once the motor is turned off and the brake is set. However, this system still has the disadvantage of low cycling rates and a time lag between motor turn on and load reaching its rated speed.

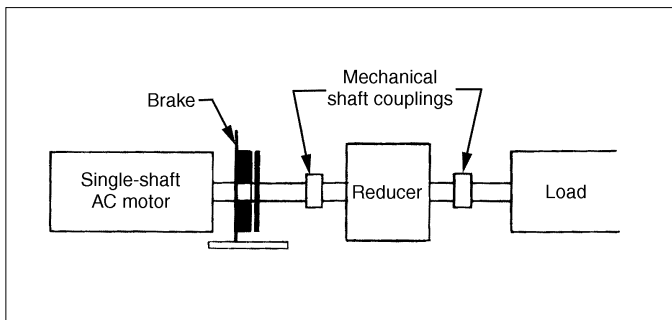

Figure 2-5

**System using a clutch-brake**

The final example consists of a motor, clutch-brake, reducer, and load (Figure 2-6). In this arrangement, the motor again runs continuously and the clutch is used to transmit power to the load. The brake is used to stop the load, providing rapid stops. Since the motor is always decoupled by the clutch when the brake is energized, the brake is only stopping the inertia of the load, not that of a motor. Advantages of this type of system are extended motor life, high cycling capability, and rapid start/stops. The clutch-brake could adapt to the C-face of both the motor and reducer. Another example would be a foot-mounted clutch-brake unit. In this case, the motor and reducer would be driven offset with respect to the clutch-brake. It would also be possible to use separate clutches and brakes to provide the clutch-brake function. However, when using separate clutches and brakes, care must be taken in sizing the various units and additionally controlling, so as to minimize any overlap between the clutch or brake activity.

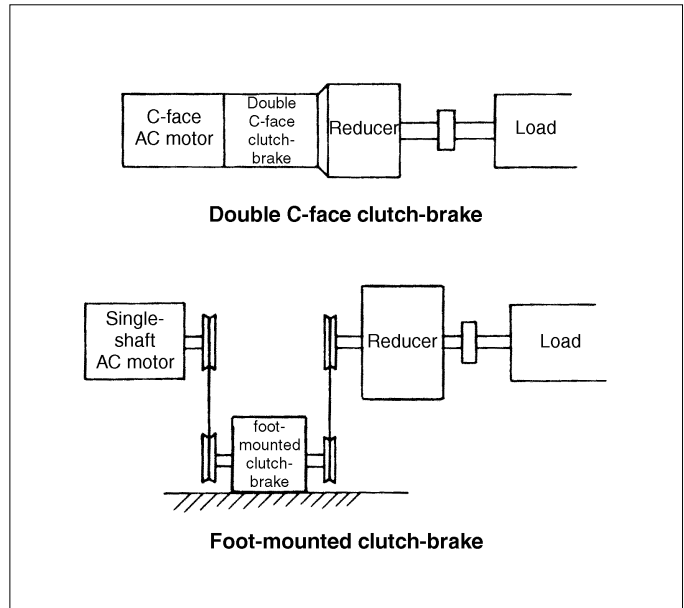

Figure 2-6: Basic power transmission system with clutch-brake

### 3. Types of Clutches and Brakes

For purposes of discussion the following examples are brakes, but clutch systems can be designed around the same operation principles.

#### Eddy current

A typical eddy current brake (Figure 3-1) consists of a segmented stationary field assembly, a field coil, and a smooth-surface brake rotor that surrounds the field assembly. A small air gap exists between the smooth-surface rotor and the stationary field assembly. In operation, direct current is applied to the field coil and an electromagnetic field is established in the stationary field assembly. If the brake rotor is turning, eddy currents are induced in it. These eddy currents react with the magnetic field in the field assembly and produce a torque that opposes motion of the brake rotor. This torque is proportional to the square of the direct current applied to the field. Figure 3-2 illustrates how torque varies with speed on several different types of eddy current brakes. The different characteristics are attributable to different designs for the stationary field assembly.

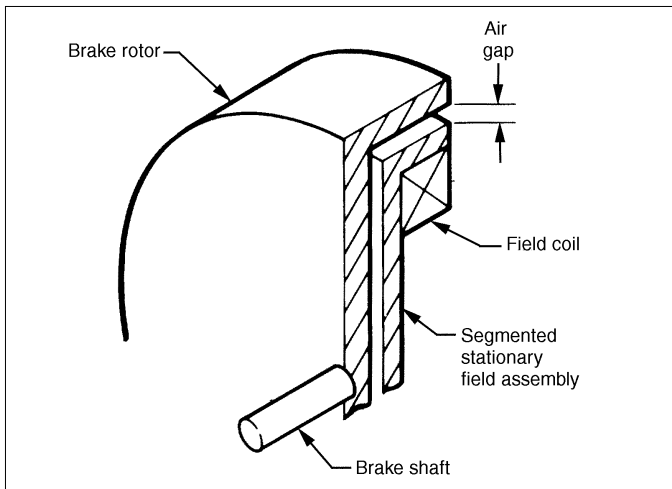

Figure 3-1: Typical eddy current brake

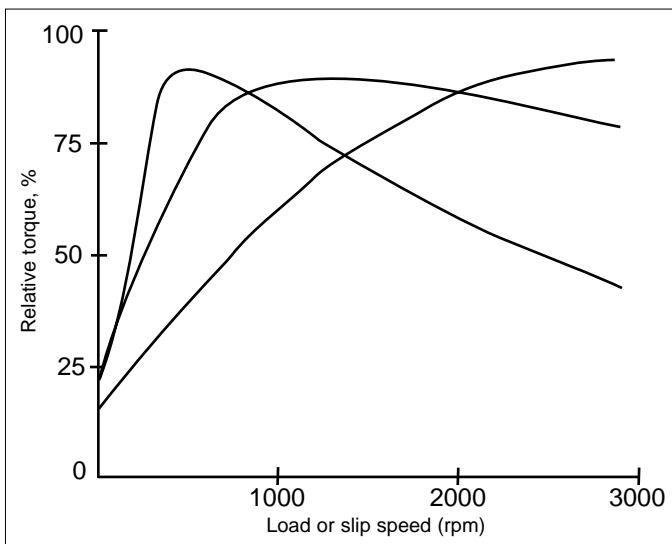

Figure 3-2: Torque characteristics for eddy current brakes

Note that at zero slip, the eddy current brake has no torque, and, therefore, cannot be used where holding is required. Eddy current brakes have good torque control and long life. They are useful for providing drag loads. The most common application is tensioning. Eddy current brakes are expensive, and frequently require special cooling provisions.

#### Hysteresis

Hysteresis braking is accomplished with two basic components.

- A reticulated pole structure including a coil to energize it
- A permanent magnet rotor

The two components are fitted together, but are not in physical contact (Figure 3-3).

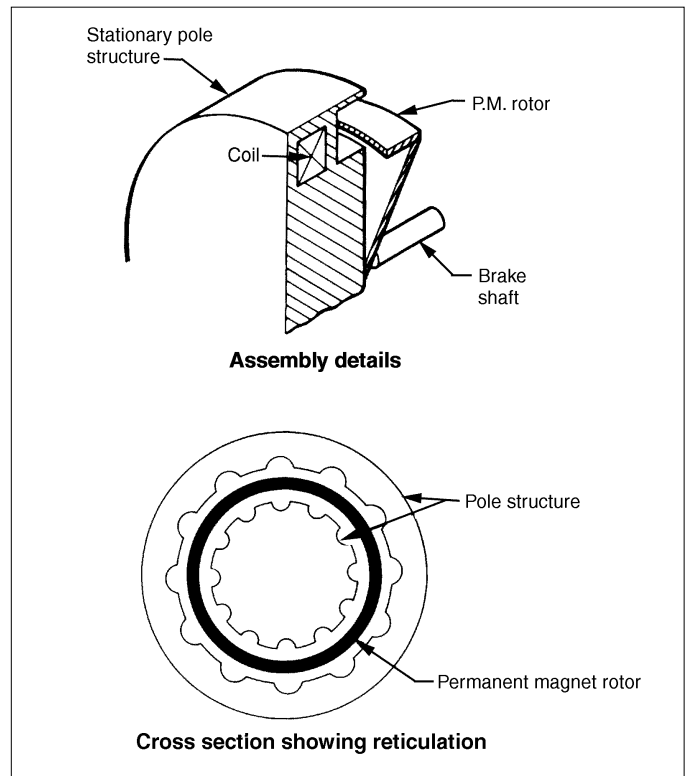

Figure 3-3: Typical hysteresis brake

When DC power is applied to the coil, an electromagnetic field develops in the air gap of the pole structure. This field is directed through the concentrically mounted permanent magnet rotor. The rotor resists motion through the magnetic field. This resistance, or *braking torque* is directly proportional to the coil current, and it is essentially independent of rotor speed throughout the range of the brake (Figure 3-4).

Hysteresis brakes provide smooth operation, long life, and excellent controllability. However, these brakes are very expensive and, for practical purposes, limited to small sizes. Typical applications for these brakes include tensioning, mechanical damping, positioning, and as a load simulator on test stands.

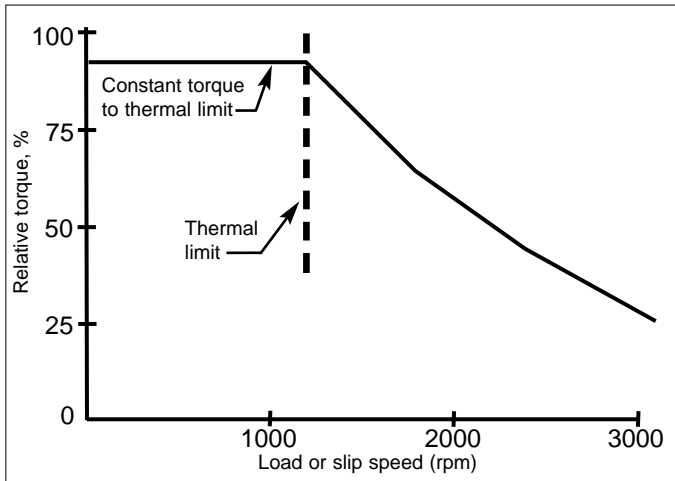

Figure 3-4: Typical torque characteristics for hysteresis brake

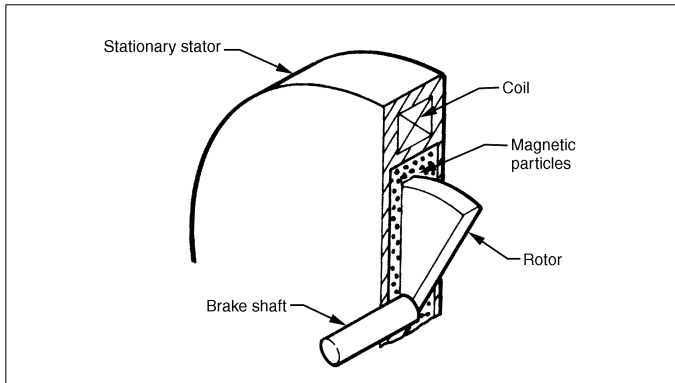

Figure 3-5: Typical magnetic particle brake

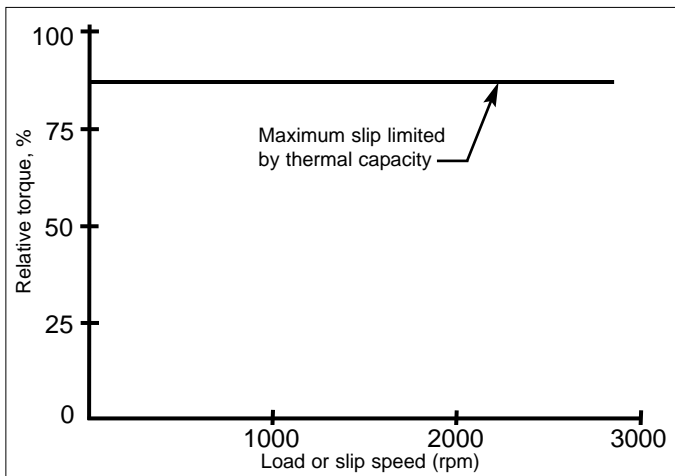

Figure 3-6: Typical magnetic particle brake torque characteristic

### Magnetic particle

The magnetic particle brake consists of a smooth rotor and brake shaft assembly that is contained within a stator. The stator also contains a DC coil (Figure 3-5). A magnetic powder composed of fine iron particles is located in the air gap between the stator and rotor.

When the coil is energized, an electromagnetic field is formed in the air gap. This field causes the iron particles to link up and bond the rotor to the stator. Since the stator is held stationary, the net effect is a braking torque on the rotor and brake shaft. The amount of magnetic particle

bonding and hence the brake torque, is directly proportional to the current flowing in the stator coil.

The torque of a magnetic particle brake is independent of speed as shown in figure 3-6. The torque can be easily adjusted by varying the current to the stator coil. Magnetic particle brakes are useful in tensioning and positioning applications, where continuous changes of speed are required.

### Mechanical

This category of brakes includes roller, ratchet, sprag, cam, and wrap spring devices. They all rely on some type of mechanical wedging action to accomplish braking. These devices are called backstop brakes or overrunning clutches, and allow rotation in one direction, while preventing rotation in the other direction.

### Friction

Friction brakes act by generating frictional forces as two or more surfaces rub against each other. The stopping power or capacity of a friction brake depends on the area in contact and coefficient of friction of the working surfaces as well as on the actuation pressure applied. Wear occurs on the working surfaces, and the durability of a given brake (or service life between maintenance) depends on the type of friction material used for the replaceable surfaces of the brake.

Friction brakes or clutches can be actuated electrically, mechanically, hydraulically, or pneumatically. Friction brakes can be operated in either of two ways. In the first, the actuator is used to engage or set the brake; a spring disengages the brake when the actuation force is removed. In the second, the brake is engaged by spring pressure or a permanent magnet, and the actuator is used to release the brake by overcoming the engaging force. This second type is frequently referred to as "fail safe" because it automatically sets if the actuator power fails or is accidentally shut off.

The torque characteristic for typical friction product is shown in Figure 3-7. The maximum torque occurs at zero slip speed and decreases as slip speed increases.

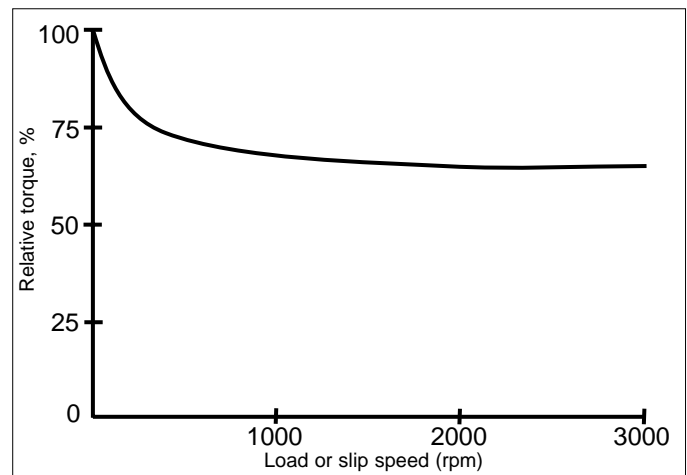

Figure 3-7: Typical torque characteristics

The major characteristics of these systems are summarized in Table 3-1.

**Table 3-1: Summary of characteristics**

	<b>First Cost</b>	<b>Available with Fail Safe Capability</b>	<b>Torque Adjustability</b>	<b>Holding Torque</b>	<b>Actuation</b>
Friction	Low	Yes, some styles	Limited	Yes	Electrical Mechanical Fluidic
Eddy current	High	No	Easy	No	Electrical (DC)
Hysteresis	High	No	Easy	Yes	Electrical (DC)
Magnetic particle	Moderate	No	Easy	Yes	Electrical (DC)
Backstop or overrunning	Low	Depends on rotation direction	None	Yes	Automatic



## 4. Principles of Friction Braking or Clutching

Friction products are simple, low cost, flexible, and reliable. They are the most practical products for use in cycling applications. When released, friction products offer minimal residual drag.

Friction products are available in a variety of styles, and can be operated with several different types of actuators. All styles, however, have two common characteristics:

- Torque
- Thermal capacity

The torque or stopping force of a friction product is created by two working surfaces rubbing against one another. For any given type of working surface material, the braking torque is dependent upon the total area of surface in contact and the contact pressure compressing the surfaces. This torque is also dependent upon the coefficient of friction (a measure of stickiness) of the devices working surfaces.

The coefficient of friction takes two forms - static and dynamic. The *static* coefficient of friction is usually higher than dynamic, and exists only when there is *no relative motion* between the products working surfaces. The *dynamic* coefficient of friction exists when there is *motion*. Hence the torque of a friction device is usually highest when there is not relative motion of the friction surfaces. This torque is called the static torque. As relative motion (slip) between the friction surfaces increases from the zero value, brake torque decreases. Normally the torque stabilizes and remains near constant at some value of slip. A typical curve showing brake torque versus slip speed is shown in figure 4-1. Note that when slip is greater than zero, torque varies with the slip speed. This torque (when slip exists) is called dynamic torque.

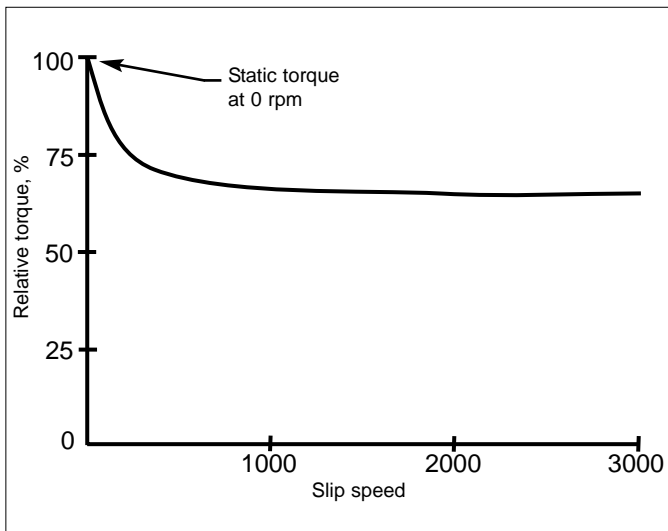

Figure 4-1: Friction torque characteristic, showing static torque at 100%

Most published clutch or brake torques are static torques. It is important to recognize and take into account the difference between static torque and dynamic torque when selecting and applying a friction product.

The other important characteristic of a friction product is its thermal capacity. Every time a friction device stops or starts a load, it converts the mechanical energy of the load into heat energy. The brake must be able to throw off or dissipate this heat energy to its surroundings. The measure of a product's ability to dissipate heat to its surroundings is called thermal capacity. If the thermal capacity is exceeded during a stop or start (heat energy input exceeds heat energy dissipated) the product's temperature increases, and could eventually cause the device to fail. Obviously, thermal capacity is another important consideration in selection.

Friction products can be actuated electrically, pneumatically, hydraulically, or mechanically. Mechanical actuation is usually accomplished with a lever or a gear arrangement. Mechanical actuation is not suited for automatic control systems.

Pneumatically and hydraulically actuated devices are similar (both rely on the movement of a fluid). In fact, many devices of the same design can be used with either hydraulic or pneumatic actuation. Actuation is usually accomplished via pistons (air or hydraulic) and pressure plates. Actuation can also be accomplished by an inflatable bladder that compresses the friction surfaces. The chief disadvantage of pneumatic or hydraulic actuation is the added cost for installation and maintenance of support equipment (compressor, pumps, valves, piping, filters, solenoid controls and exhaust mufflers).

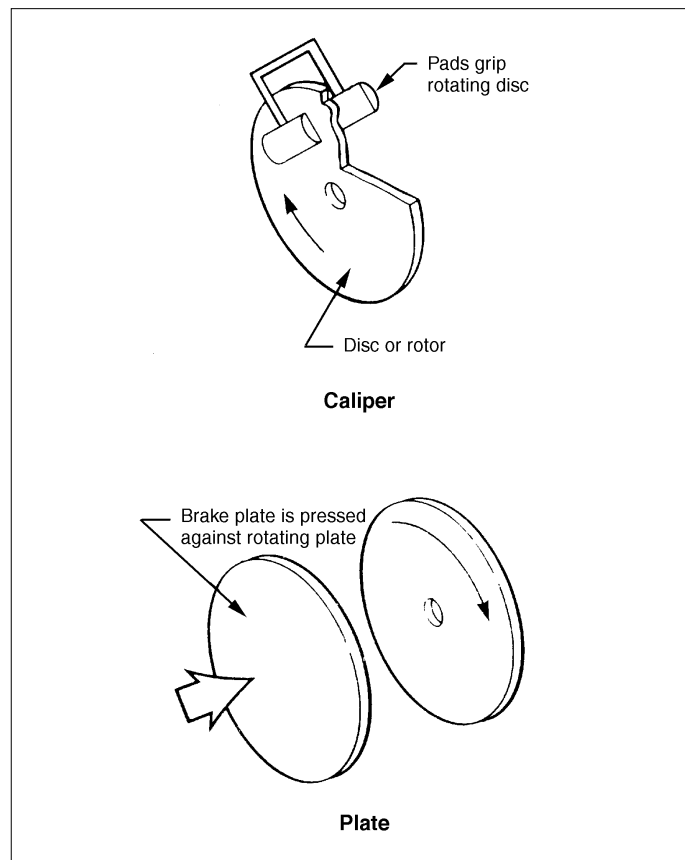

Figure 4-2: Typical disc brake types

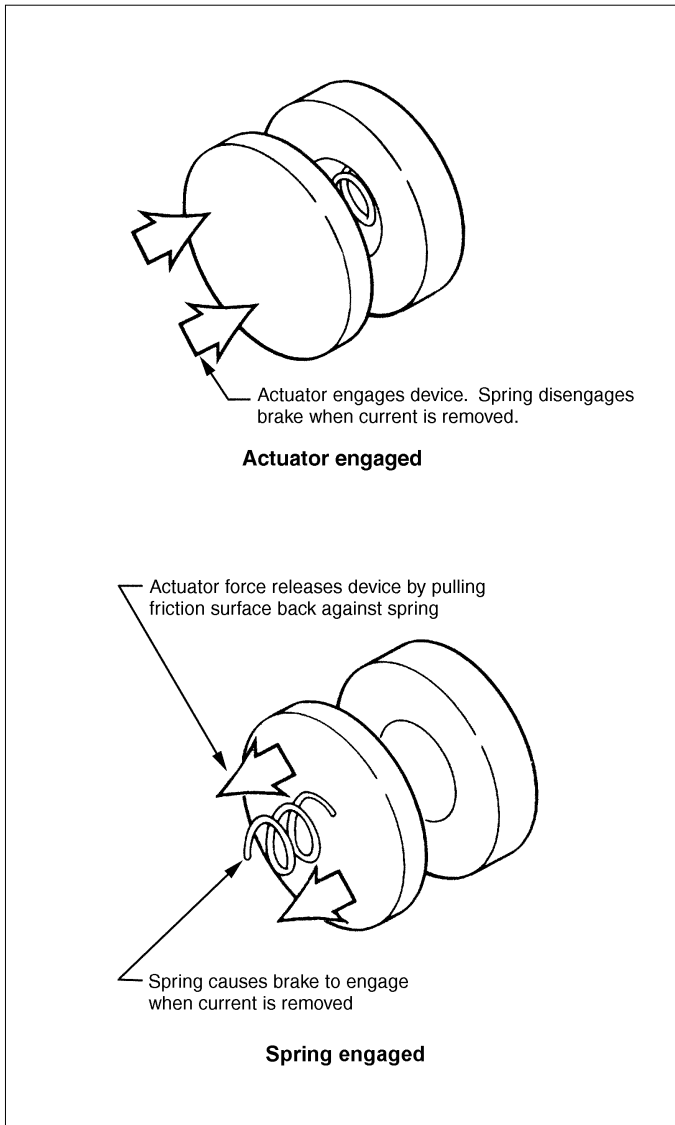

Figure 4-3: Two modes of friction operation

Electrical actuation allows extremely fast reaction and cycle rates. It is also well suited for remote and automatic control. Electric actuation allows a great deal of control flexibility, and permits direct interface with computerized controllers.

Stearns Division manufactures three basic friction product lines:

1. Spring-set brakes — plate types that are spring set and electrically released.
2. Electrically engaged products — plate disc (single surface) type that are electrically set. These are direct acting and DC actuated.
3. Heavy duty products — plate disc type that are spring set and electrically released or electrically engaged. These products are direct acting and DC actuated.

## 5. Principles of Electrically Actuated Friction Clutches and Brakes

Friction products are simple, low cost, flexible, and reliable. They are the most useful in systems where rapid cycling is desirable.

Stearns DC products are actuated by electrical means, specifically direct current – voltage. (AC can be accommodated by use of a rectifier).

To understand how clutches operate, it is necessary to have a basic understanding of electromagnetism.

Everyone should be familiar with the horseshoe magnet as shown in Figure 5-1a. If a steel bar is placed near the magnet, a magnetic force is exerted on the steel bar, and it is attracted toward the magnet. The ends of the horseshoe magnet are called poles. This type of magnet is called a permanent magnet. It is made of a material that, once magnetized, retains the magnetism over a long period of time.

An electromagnet as shown in Figure 5-1b is very similar to the horseshoe magnet. The main difference is the material from which it is made. An electromagnet is made of a material that is easily magnetized but loses its magnetism quickly after the magnetizing force has been removed. It requires an external means to provide a magnetizing force. In our case, it is a DC electric coil wound around one of the legs of the horseshoe shape. When a direct current flows through this coil, a magnetic force is induced in the horseshoe magnet, and it operates the same way as a permanent magnet with one exception. Once the current is removed, the magnet force disappears and the bar is no longer attracted to the electromagnet.

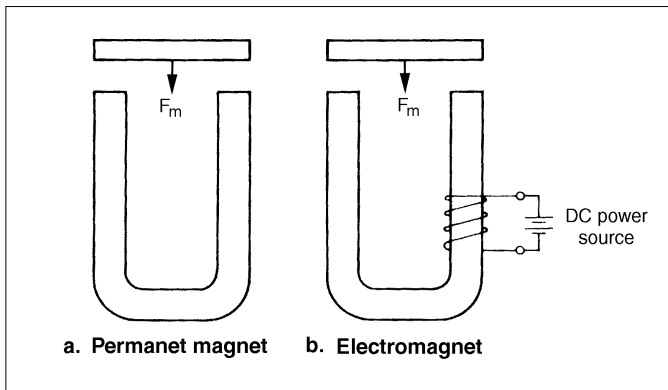

Figure 5-1: Simple horseshoe magnets

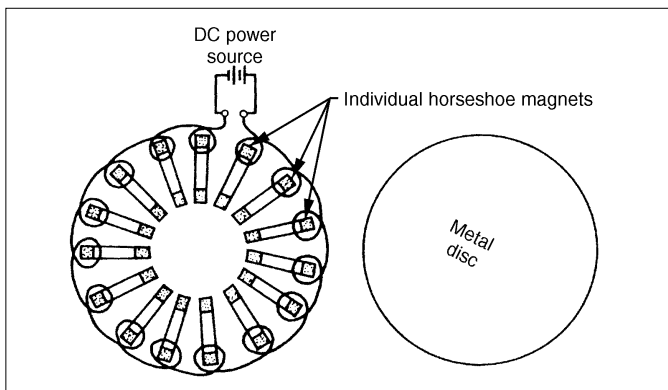

Figure 5-2: Ring of horseshoe magnets

To show how this relates to an electromagnetic clutch or brake, assume for the time being that we have a large number of horseshoe electromagnets arranged in a circle as shown in Figure 5-2. A coil is wound around a leg of each electromagnet. When the electromagnets in this configuration are energized, they would be able to attract a metal disc and hold it. Once the direct current voltage was turned off, however, the disc would be free to fall away.

If an arrangement of electromagnets like that shown in Figure 5-2 were required, it would be very difficult and expensive to build because of the many parts involved. A simpler way of building such an arrangement would be to use a ring with a horseshoe cross section as shown in Figure 5-3. The coil around each leg is replaced by one donut-shaped coil. This magnetic profile is almost identical to the magnet body of the DC clutch or DC brake.

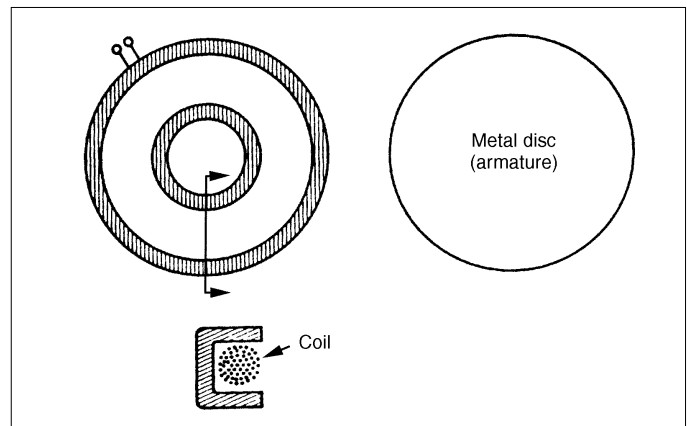

Figure 5-3: Ring electromagnet with horseshoe cross-section

There is no known insulator of magnetic lines of force. However, these lines of force tend to take the path of least resistance. Certain materials offer an easier path for magnetic flux, while others offer more resistance. This difference in material characteristics is called reluctance. For example, soft iron has low reluctance and therefore offers a low resistance path for magnetic flux. On the other hand, air has a high reluctance and offers a greater resistance to magnetic flux. If iron were placed in a magnetic field, the flux would tend to concentrate in the iron as much as possible, rather than take a path through air.

Knowing the reluctance of various materials and knowing that magnetic lines of force will take low reluctance paths where possible, we are able to direct and control magnetism and put it to work.

A cutaway drawing of an electromagnetic clutch-coupling is shown in Figure 5-4. An exploded view of the same unit is shown in Figure 5-5. The four main parts of this clutch-coupling are the magnet body (note the horseshoe cross section), drive hub, armature, and driven hub. As its name implies the clutch-coupling performs two functions: a clutching function and a coupling function between two shafts, which are not necessarily the same size. The clutch-coupling works in the following manner. The drive hub is mounted on one of the shafts to be coupled. The

magnet body is isolated from rotation of the drive hub by a bearing. This isolation is necessary because if the magnet body were allowed to rotate the coil leads would quickly wind around the magnet body and separate. A small restraining tab is located on the magnet body. It is used to restrain the magnet body from rotating. The driven hub is attached to the other shaft to be coupled. The driven hub has a male spline outside diameter. The armature has a splined inside diameter which rides on the driven hub. This permits the armature to move back and forth axially while restraining it from moving radially with respect to the driven hub.

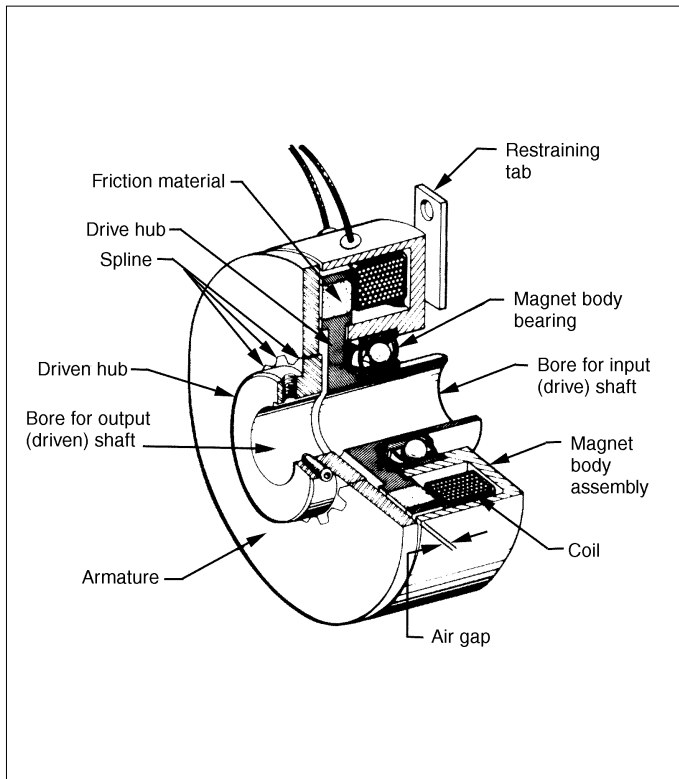

Figure 5-4: Cutaway of DC clutch - clutch coupling (CCC)

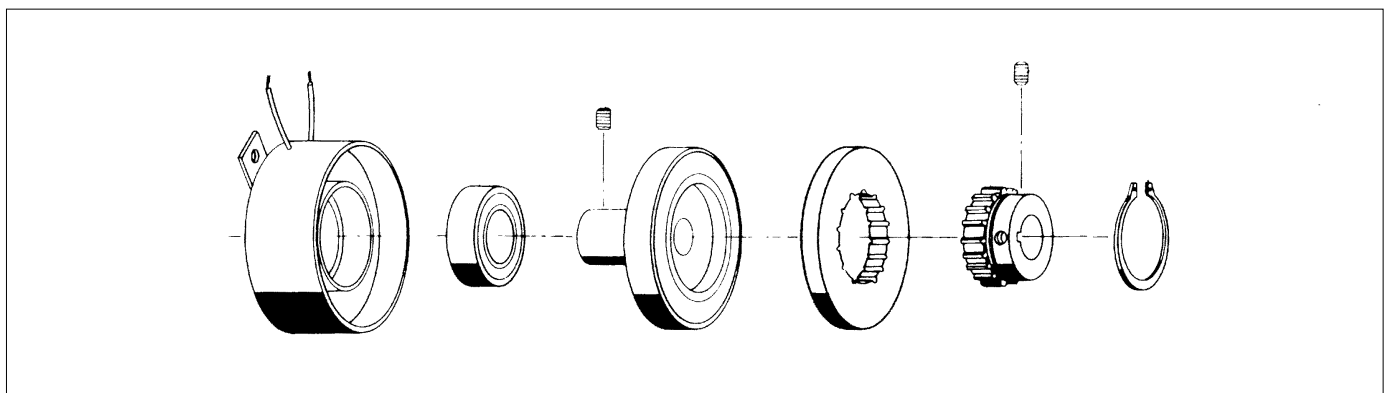

Figure 5-5: DC clutch - clutch coupling (CCC)

To set the clutch-coupling up for proper operation, the two shafts must be aligned and the drive hub and driven hub must be attached in a manner to establish an appropriate air gap between the armature and the drive hub. When DC voltage is applied to the coil of the clutch, a magnetic force is induced in the magnet body and passes thru the drive hub to attract the armature towards the drive hub. When the armature is drawn to and clamped against the drive hub by this magnetic force, the driven hub will rotate at the same speed as the drive hub. When the DC voltage is turned off, the magnetic force will also be turned off and the armature will be decoupled from the drive hub, and differential rotation can occur.

The clutch operates in much the same manner as the clutch-coupling. However, the clutch is used in an offset drive situation with a sprocket, pulley, sheave, etc. A typical clutch is shown in Figures 5-6 and 5-7. The main parts are again the magnet body, drive hub, armature, and driven hub. The magnet body and the magnet body bearings can be identical to that of a clutch-coupling. The main differences between the clutch and clutch-coupling are in the

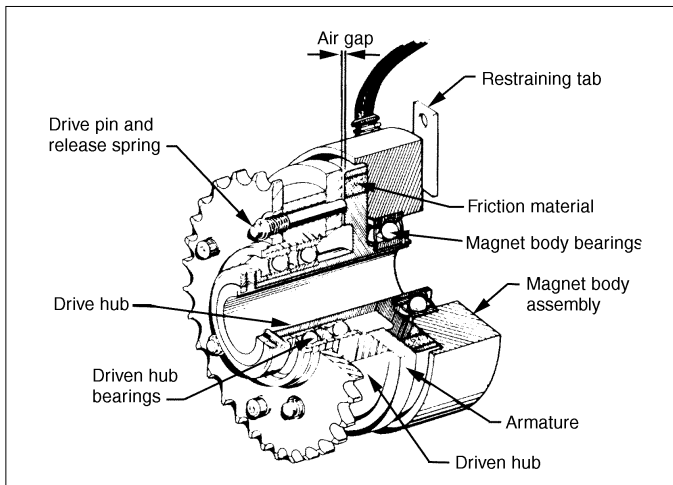

Figure 5-6: Cutaway CRS clutch - Roto Sprocket® with adapter hub

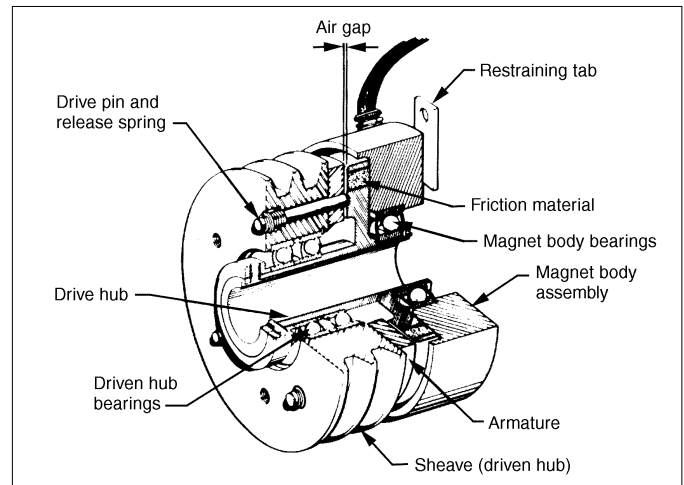

Figure 5-8: Cutaway CRP clutch - Roto Sheave®

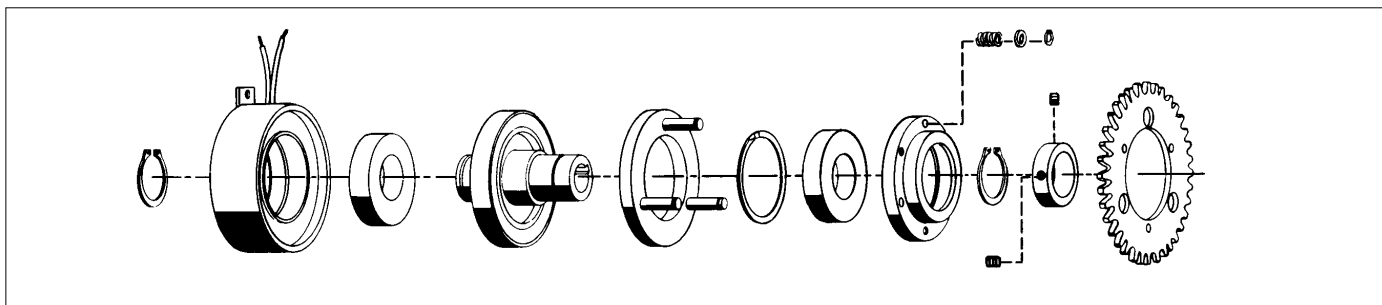

Figure 5-7: Exploded view CRS clutch - Roto Sprocket®

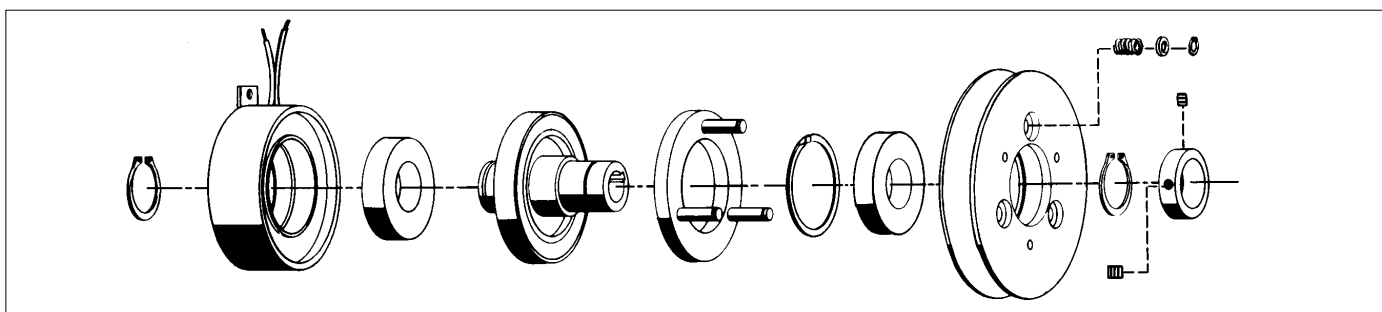

Figure 5-9: Exploded view CRP clutch - Roto Sheave®

The last type of unit to be described is a packaged clutch-brake combination. For discussion purposes a foot mounted unit with input and output shafts will be reviewed. Briefly, a clutch-brake allows the motor to run continuously while the clutch-brake mechanism starts and stops the load. This allows the motor's inertia to assist in picking-up and starting of the load. Additionally a clutch-brake eliminates repeated high starting currents in the motor and permits multiple starts and stops per minute.

Figure 5-10 shows a cross section of a clutch-brake in the "brake" mode. This is a Super-Mod™ model of a Stearns SM 50-1020. During normal operation, the drive hub (A) is rotating at motor speed, the brake coil is energized, the brake armature (C) is magnetically attracted to the brake friction face (D) with the holding or braking torque developed the output shaft will not rotate. Note that there is an air gap between the input drive hub (A) and the clutch armature (B). Therefore, no power is transmitted through the clutch-brake from the motor. This "brake" mode also allows for the initial no-load start up of the motor.

Figure 5-11 shows the same clutch-brake in the "drive" mode. The rectifier control or power supply de-energizes the brake coil and then, immediately the clutch coil is energized. The electromagnetic field generated in the clutch magnet body magnetically attracts the clutch armature (B) to the drive hub (A). Note that there is now an air gap between the brake armature (C) and the stationary friction face (D). Holding or braking torque is no longer developed.

Since the drive hub (A) is rotating with the motor, the clutch armature (B) begins to rotate due to the frictional force developed by the magnetic attraction between the clutch armature and drive hub. Rotational force (torque) from the motor is now transmitted from the input shaft, through the drive hub, to the clutch armature, to the splined hub (E), to the output shaft and causing the driven equipment to rotate at motor speed. The brake armature (C) also rotates with the clutch armature since they are both mounted on the same splined hub. The brake armature is pulled out of contact from the stationary friction face (D) by the release spring so that no braking effort or drag occurs.

To complete the cycle, the clutch coil is de-energized and then the brake coil is energized (Figure 5-10). The sequence is the clutch coil's electromagnetic field diminishes and stops attracting the clutch armature and the release spring pulls the clutch armature out of contact with the drive hub. Rotational force from the motor is no longer transmitted. In addition, the brake coil's electromagnetic field is building up and attracts the brake armature to the stationary friction face. Braking torque due to this frictional force is developed and the driven equipment is stopped and held.

A clutch-brake is simply an electromechanical means of coupling and decoupling a motor to a load.

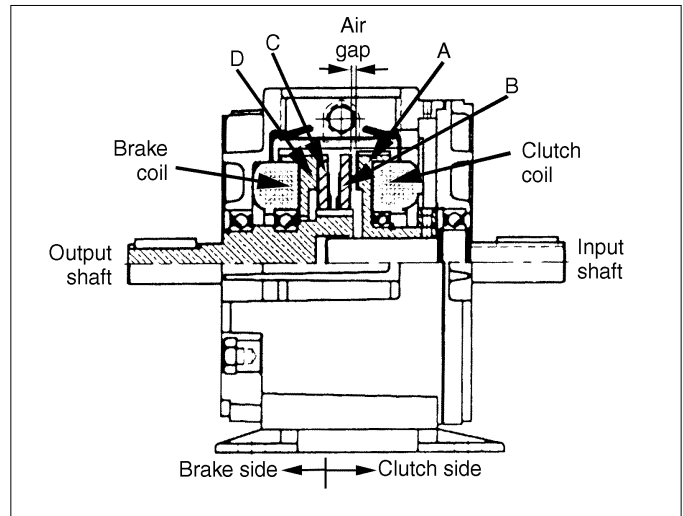

Figure 5-10

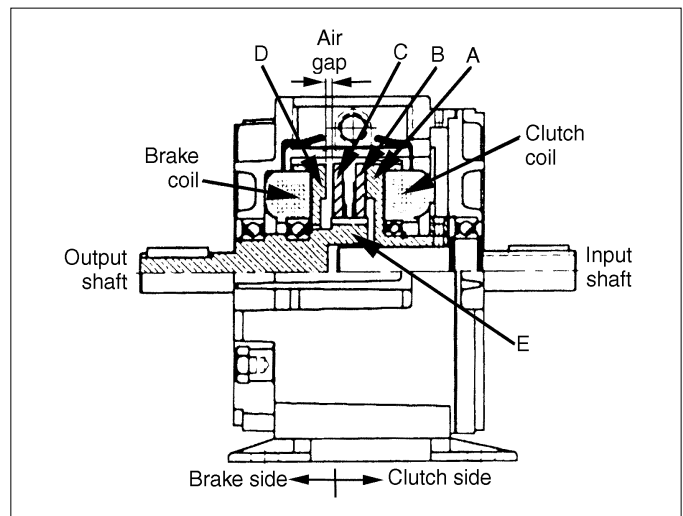

Figure 5-11

- A - Drive Hub
- B - Clutch armature
- C - Brake armature
- D - Brake friction face
- E - Splined hub

## 6. Basic Rectifier/Power Supply Controls

Electrical operation is the easiest method to control clutches and brakes, and electromechanical clutch and brake systems are the easiest to install. Just wire the rectifier control, and a switch as simple as a remote push button can operate the clutch or brake. Automatic switches will most likely be used, and any switch type input such as limit switches, relays, timers, counters, proximity switches, photoelectric sensors, programmable controllers or computer commands can be used to activate the clutch and/or brake.

Stearns DC clutch-brake products operate on direct current (DC) voltage as we stated. This electrical power can be supplied by:

1. A rectifier control power supply with a fixed DC voltage output.
2. A rectifier control power supply with variable DC voltage output for softer starts and/or stops.
3. Stearns Tor-ac rectifier design which is built into the DC product.

The primary function of the rectifier - power supply is to convert alternating current voltage to direct current voltage. A rectifier control is only necessary when a suitable source of DC power is not available.

Selection of a rectifier control is straight forward. Any Stearns rectifier control can be used with any clutch or brake, provided the power output is sufficient for the power draw of the clutch or brake.

A few considerations are involved: Available AC line voltage, single or double control circuit, torque adjustment and could a Tor-ac® unit be used.

The nominal input voltage rating of Stearns rectifier controls is 115 VAC. If 230 or 460 VAC is desirable to use and a separate 115 circuit is not a good alternative, a step down transformer is suggested as a cost effective method. The nominal output voltage from Stearns rectifier controls is 100 VDC.

In general, rectifier controls are available for single circuits (clutch or brake alone) or double circuits (clutch/ brake packaged units). Double circuit controls are usually used with a clutch-brake combination to perform a start-stop function; however, they could also be used with two clutches for performing a speed change, or two brakes to stop and hold alternating work stations. Consult the factory when more than one device is to be operated on any single circuit or where more than two devices are to be operated from a double circuit control.

If an application requires a torque lower than that of the clutch and/or brake rating, or if the torque must be adjusted to fit the system load (soft start or stop), an adjustable output rectifier control can be used. The torque adjustment of the clutch and/or brake is accomplished by varying the output voltage from the control. This concept is similar to the volume control on a radio. The safe workable range of adjustment, particularly when using spring release clutches or brakes, is between 1/3 to full rated torque of the friction product. Note: While reducing the torque of the will allow some slippage to occur, more wear likely will result.

Additionally, the device must be sized so that its fully engaged torque is adequate to drive the load without further slippage.

Lastly, could a Tor-ac equipped product do the job? It could minimize the hookup wiring, and eliminate any concern about rectifier selection.

A Tor-ac control is a rectifier - control that has been built into the clutch or clutch-brake. Its solid-state circuitry and quick response circuit design allows for the switching to be done on the AC line side of the control, with response times equaling that of DC side switching as provided by other more conventional rectifier controls.

Two additional topics that need review are tension controls and overexcitation controls.

Friction clutches and brakes can be used on limited unwind or tensioning applications where the level of tension control is not too critical and where the life of the brake or clutch under slipping conditions is acceptable. More commonly used tensioning devices are: Eddy current brakes and drives, hysteresis brakes, magnetic particle clutches and brakes, and Servo-motor controlled systems.

The controls for tensioning generally vary the power applied to the clutch or brake device to match a desired or set level of tension. Feedback information for the power adjustment can take many forms, the more common ones being:

- Dancer arms
- Powered dancer arms
- Follower arms

Tension controls are used in composite material processing, filament winding, fine wire handling, optical fiber manufacturing, thin film, foil and paper handling, pultrusion fiber delivery systems, stretch wrap delivery equipment and strapping machinery.

Overexcitation controls provide certain advantages when used with clutches and brakes, such as improved clutch/brake life, stop/start consistency, reduced heat input to the clutch/brake, improved response time and higher cycle rates.

Overexcitation controls deliver a spike voltage to a DC clutch or brake coil, up to five times the normal rated coil voltage. This voltage spike reduces the coil saturation time, and provides for faster magnetic field build up. This dramatically reduces the mechanical engagement of the mating clutch or brake components and minimizes slippage and frictional heat.

To review some of the advantages of clutches and brakes:

1. Cycles of operation can be automatically or manually controlled by timers, limit switches, photoelectric systems, etc.
2. Extended motor life under rapid cycling conditions. Attempting to use electric motors under such high cycling conditions would likely cause the motor to overheat and fail.

3. Reduce overall electrical power consumption from utility companies. The electric motors are running continuously and the clutch-brakes accomplish the starts and/or stops, therefore the high current draw of a motor start-up under load is avoided.
4. The motor's inertia is put to useful work, by being available to help start and accelerate a load.
5. Provides a simple and easily controllable means to mechanically connect and disconnect a load from a motor or other prime mover source.



## 7. Two Step Selection Procedure

For most applications where starting or stopping *time* and *distance* is not an important factor, a simple two step selection is all that's necessary.

STEP ONE: Determine function and type

**Table 7-1**

Function	Type
When power is to be transmitted between two in-line shafts.	Clutch-coupling
When power is to be transmitted to a parallel shaft.	Clutch
When stopping a load	Brake
When starting and stopping of a load is required.	Clutch-brake

**Table 7-2a: Electrically set clutch and brake unit size selection chart** CAUTION: Rpm refers to shaft speed at clutch or brake. Based on 2.75 service factor.

rpm x hp	2	4	6	8	10	12	15	18	20	24	30	36	40	46	50
1/20															
1/12															
1/8															
1/6							3								
1/4															
1/3															
1/2							3.5								
3/4															
1							5								
1 1/2															
2							5.5								
3															
5															
7 1/2							8								

Note: Do not use this chart for AAB or SM unit selection.

**Table 7-2b: Super-Mod selection chart**

CAUTION: Rpm refers to shaft speed at clutch or brake. Static torque selection based on a typical electromechanical-friction clutch service factor of 2.75

rpm hp	200	400	600	800	1000	1200	1500	1800	2100	2400
1/8										
1/4										
1/3										
1/2										
3/4										
1										
1 1/2										
2										
3										
5										
7 1/2										
10										

Frame size and shaft diameter may affect selection and should be considered. See manufacturer's dimensional and sizing information.

Example:  $\frac{(3 \text{ HP} \times 5252)}{1750 \text{ rpm}} \times 2.75 = 24 \frac{3}{4}$

STEP TWO: Determine size

To select the correct clutch and brake size, use Table 7-2a. To select the correct Super-Mod unit size, use Table 7-2b. These charts are set up so that units selected have a safety factor exceeding the motor torque capability based on NEMA design B motors. Unit size is based on motor horsepower and shaft speed in rpm at the clutch or brake. To use the selection chart, locate motor horsepower along the vertical left-hand axis and shaft speed along the upper horizontal axis. The proper size will appear at the intersection of the horsepower row and the rpm column. If there is a choice of locations for the unit being selected, pick the highest speed shaft to minimize unit size. CAUTION: The rpm to be used for selection is the rpm "at" the clutch or brake.

The sizes given in Tables 7-2a and 7-2b are for NEMA design B motors. These calculations are based on the torque equation given below. This equation can also be used for applications where the prime mover is something other than a design B motor.

$$T = \frac{hp \times 5252}{N} \times SF$$

Where:

T = Average dynamic torque, pound-feet (lb-ft)

hp = Horsepower of prime mover. If the horsepower requirement of the load is known to be less than that of the prime mover (i.e. and engine driven auxiliary pump), that horsepower can be substituted here.

N = rpm at clutch or brake

SF = Service factor for the prime mover; peak torque capability.

Some sample service factors are given for reference:

**Table 7-3**

Application	Service Factor (SF)
DC brake holding only	1.0
DC brake stop and hold	1.5 – 2.5
NEMA design A, B & C motors	2 – 4
NEMA design D motor	3 – 5
Gasoline and diesel engines	5 – 10

## Precautions

This two-step selection procedure can be used for sizing most clutch-brake applications. Example of the few situations where it should not be used are as follows:

1. Applications where it is necessary to start or stop the load within a given time.
2. Applications involving high cycling rates.
3. Applications where there is a large flywheel effect on the drive or driven side of the clutch or brake.
4. Applications where the ambient temperature is not within 0° to 40° C (32° to 104° F).
5. Applications below 300 rpm.

In these type of applications, further calculations must be made by the customer prior to selecting the proper size unit or be referred to an application engineer for selection assistance.

## Application examples

Although the clutch and brake selection procedures are basically straight forward, the following examples in the use of the selection chart will illustrate an approach to solving the application problem.

**CASE ONE:** A motor is connected directly to a load input shaft (Figure 7-1). The motor is a standard NEMA B design and rated at 2 horsepower with a base speed of 1800 rpm. A clutch is to be used to prevent premature motor “burn out” due to the energy that the motor has to dissipate when accelerating the load. As the motor shaft is to be connected to the load shaft, a clutch coupling is required.

Referring the motor horsepower and base speed to the clutch selection chart 7-2a, the selection is a size 5.5 clutch coupling (CCC-55).

**CASE TWO:** A motor is connected to a load thru a 10:1 gear reducer (Figure 7-2). The clutch must be applied to the low speed shaft due to space limitations. The motor is a standard NEMA B design and rated at 1 horsepower with a base speed of 1800 rpm. The reducer shaft is to be connected to the load shaft; therefore, a clutch coupling is required.

Referring the motor horsepower and the reducer output speed to the clutch selection chart 7-2a, the selection is a size 8 clutch coupling (CCC-80).

**CASE THREE:** A motor is connected to a load thru a reducer with a further belt reduction on the output of the reducer (Figure 7-3). The motor is a standard NEMA B design and rated at 1 horsepower with a base speed of 3600 rpm. The gear reducer has a 2:1 ratio. The belt reduction is 4.5:1. A clutch and brake are required to extend motor life and provide for additional cycles per hour. Minimum down time, and easy clutch-brake maintenance without shifting equipment are primary requirements. Therefore, a foot mounted clutch-brake combination is selected. There are three possible locations for the unit: (1) between the motor and the reducer, (2) on the output shaft of the reducer, and (3) on the input shaft of the load. Referring the motor horsepower and the three speed conditions of the clutch selection chart, the selections are:

1. 1 hp at 3600 rpm – SM-50-2030B
2. 1 hp at 1800 rpm – SM-50-2030B
3. 1 hp at 400 rpm – SM-180-2030B

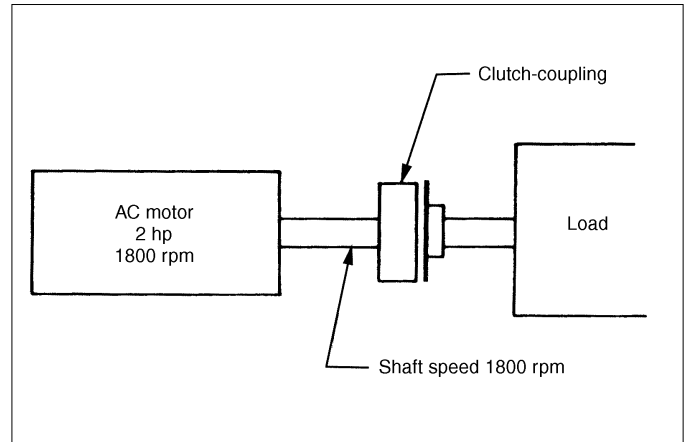

Figure 7-1: Case one application example

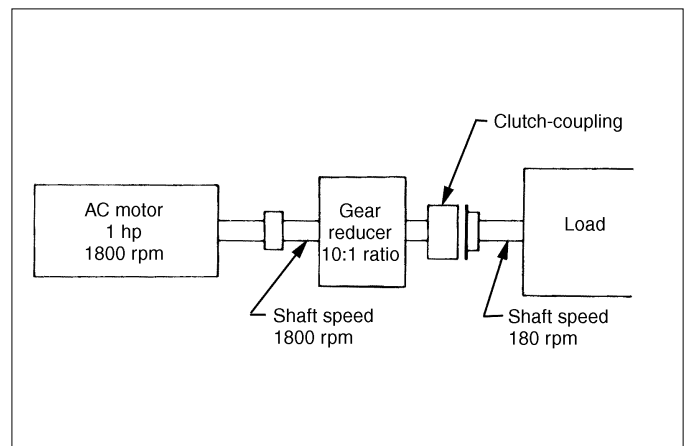

Figure 7-2: Case two application example

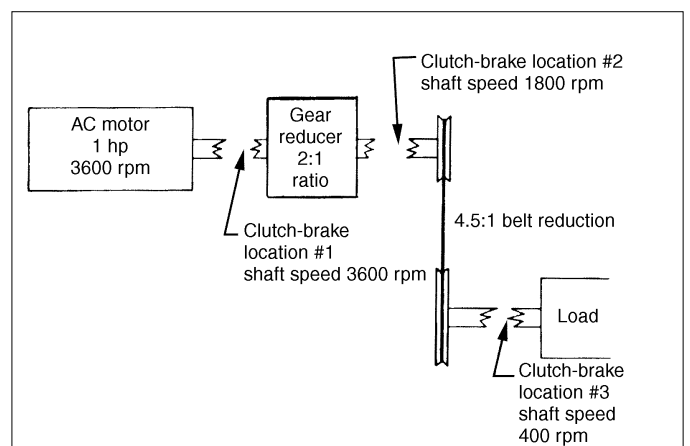

Figure 7-3: Case three application example

## 8. Engineering Fundamentals and Detailed Selection Procedure

The following presentation explains the common methods of using information about the application to select the proper clutch or brake. The information presented may be applicable to other types of clutches and brakes, however, the emphasis has been on the single disc direct acting type of clutches and brakes. The application engineering formulas presented are developed to show how they relate to the basic torque formulas and terms used every day in the power transmission industry. The intent has been to point out what factors in an application are important and to explain why.

### Fundamentals of power transmission

In order to better understand the application of Stearns brakes and clutches, it is necessary to again review the basic terms and mechanical laws of elementary physics. The following information deals with these basic terms and mechanical laws.

#### Force

A force is defined as that which tends to cause motion and can be either a push or a pull. It is usually expressed in the English system of weights and measures of ounces, pounds, tons, or "newtons".

#### Torque

Torque is derived from the Latin term "torquere" which means "to twist". Technically, torque is a *force* which produces a *twist* or *turning effort*.

In the application of clutches and brakes, as in the rest of the power transmission industry, torque is the basic dimension from which many of the more complex computations are derived. The first part of our review will show the basic torque formula is used throughout the power transmission industry.

There are two values which determine torque. They are:

1. Force
2. Distance

If a force is applied to a jack handle at some distance from the lug nut on a wheel, torque is developed. Furthermore, if the jack handle is made longer, the magnitude of torque applied to the wheel nut is greater. Therefore, the distance at which the force is applied is measured from the center of rotation.

The most basic formula to determine torque is:

$$T = F \times R$$

Where:

F = Force expressed in weight: e.g., lbs.

R = Radius at which the force is applied from the center of rotation expressed in terms of distance: e.g., ft.

T = The product of F X R expressed in lb-ft

In example A in next column a weight is hung at the perimeter of a wheel causing a pulling force to act at the radius of the wheel. The torque developed is:

$$T = F \times R$$

$$T = 2 \text{ lb} \times 3 \text{ ft}$$

$$T = 6 \text{ lb-ft}$$

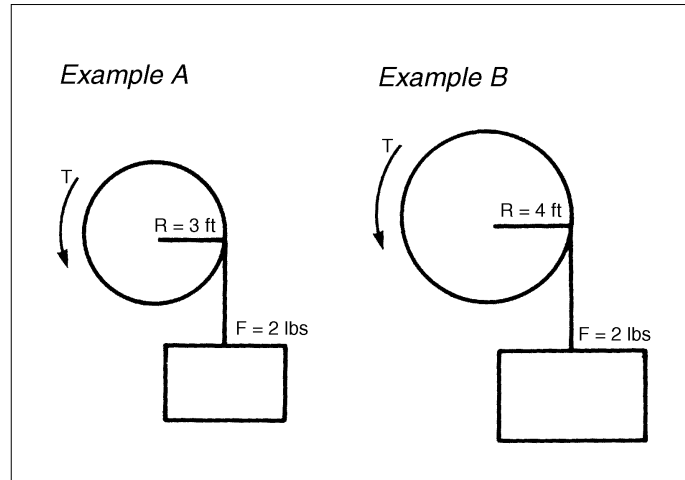

In example B above, the same force in the form of a 2 lb weight is applied at the perimeter of a larger wheel causing a pull to act at the radius of the wheel. In this case, the torque developed is:

$$T = F \times R$$

$$T = 2 \text{ lb} \times 4 \text{ ft}$$

$$T = 8 \text{ lb-ft}$$

#### Work

In our car wheel example, when force was applied to the jack handle, torque was applied to the lug nut. If we cannot move the handle, no work is being done; however energy is expended. Torque can be present without any work being done. However, as soon as the jack handle moves, work is being done.

The values that determine how much work is done are *force* and the *distance the force moves*.

$$\text{Work} = \text{distance} \times \text{force}$$

If a man moves 2,000 boxes that weigh 1 lb each a distance of 5 feet, he accomplishes 10,000 ft-lbs of work.

$$W = D \times F$$

$$W = 5 \text{ ft} \times 1 \text{ lb} \times 2000$$

$$W = 10,000 \text{ ft-lb}$$

It makes no difference in what time frame he does this work. If the task is completed in one second or one century, it is still 10,000 ft-lbs of work. When the concept of time is added to work, the result is power.

In rotational machinery, any point at a radius of "R" from the center of rotation, will travel a distance equal to  $2\pi R$  for each revolution (1 REV = TIR). Therefore, the total distance moved will equal  $2\pi R$  times the number of revolutions the point makes.

$$W = (2 \times \pi \times R) \times N \times F$$

Where N = number of revolutions

This expression can be rewritten as:

$$\text{Work done} = (F \times R) \times 2\pi \times N$$

Earlier it was determined that torque equals F X R, therefore:

$$\text{Work done} = \text{torque} \times 2\pi \times N$$

## Horsepower

Power, in mechanics, is the product of force and distance divided by time; it is also stated as the performance of a given amount of work in a given time.

*Kilowatts* and *horsepower* are the two values commonly used to express power. In power transmission systems we most frequently use horsepower. This measurement was developed by a Scottish Engineer, James Watt, who examined the concepts of work and power, or the rate of doing work by using English Dray horses. He found that on average, one horse could do work at a rate of 33,000 ft-lbs per minute. This rate came to be called horsepower and is the standard unit of mechanical power used today.

$$1 \text{ hp} = 33,000 \text{ ft-lbs/min}$$

In our previous example, if the man who moved the 2,000 one pound boxes did so in 50 minutes, then the average horsepower expended was:

$$\text{hp} = \frac{50,000 \text{ ft-lbs}}{33,000 \frac{\text{ft-lb}}{\text{min}}}$$

$$\text{hp} = .006$$

Note that horsepower is a "rate" of doing work. As such it is sensitive to time, therefore, it takes more horsepower to do a given amount of work in a shorter period of time than a longer period of time.

This is of particular importance in clutch applications where the clutch is sized at motor running torque, but used to start a heavy load. The customer may say that the clutch will see 7 hp but he uses a 10 hp motor. The clutch must be able to transmit the highest horsepower demanded and if it can't, it will slip and eventually burn up.

### Relationship between work, torque, horsepower and speed

It was previously determined that:

$$\text{Work} = \text{torque} \times 2 \pi \times N$$

and since,

$$1 \text{ hp} = 33,000 \text{ ft-lbs per minute of work}$$

therefore:

$$\text{hp} = \frac{\text{torque} \times 2 \pi \times N}{33,000}$$

Since,

$$\frac{2 \pi}{33,000} = \frac{1}{5,252}$$

Where:

N = Number of revolutions

T = Torque

The horsepower formula can be reduced to:

$$\text{hp} = \frac{T \times N}{5,252}$$

or, solving for torque:

$$T = \frac{\text{hp} \times 5,252}{N}$$

This is the basic formula used in the application of power-transmission products. It is also the basic formula used in the application of clutches and brakes. It shows clearly the factors most readily available in application

problems, i.e., hp and rpm. Furthermore, it shows that torque selection is a function of the physical forces, work and time required by an application. These factors are all obtainable if you know what to look for.

Friction clutches and brakes have two different torque ratings; *static* and *dynamic*.

*Static torque* - is defined as the torque between friction surfaces at the point when relative motion first occurs between the surfaces. This is sometimes referred to as "breakaway" torque and can be further defined as the maximum "holding" torque.

*Dynamic torque* - is defined as the torque that exists between two friction surfaces that have relative motion between them. The dynamic torque is always lower than the static torque and will vary in value with the slipping speed. The dynamic torque is of the lowest value at the highest slip differential and approaches the static torque as the slip differential approaches zero.

The reason for the different values of static and dynamic torque is due to the different frictional forces. The frictional force between two stationary objects, (static) is greater than the frictional force between the same two objects where there is relative motion (dynamic).

Pushing a heavy carton across the floor is an everyday example of the difference between static and dynamic frictional forces. A certain amount of force is required to overcome the static frictional force between the carton and the floor. However, once the carton is moving, the force required to keep it moving (and overcome the dynamic frictional force between the carton and floor) is substantially less.

Shown in Figure 8-1 is a typical dynamic torque curve which represents what would normally happen to the torque of a clutch or brake as the relative speed between the drive and driven elements of the unit increases. Note that at 0 rpm speed difference, the actual torque is equal to the rated static torque and as the relative speed increases, the transmitted torque decreases.

This concept is particularly important in beginning to understand the application of clutches and brakes because it describes a key characteristic of the product. That is complete engagement is not instantaneous. It takes some amount of time to overcome the inertia caused by the speed difference between the drive and driven elements. Therefore, 100% of the torque that a unit is capable of transmitting, will not actually be transmitted at the moment the unit is activated and this fact must be taken into account in making a clutch or brake selection. There will be some delay caused by inertia between the time of activation and the time that a unit is transmitting the rated torque.

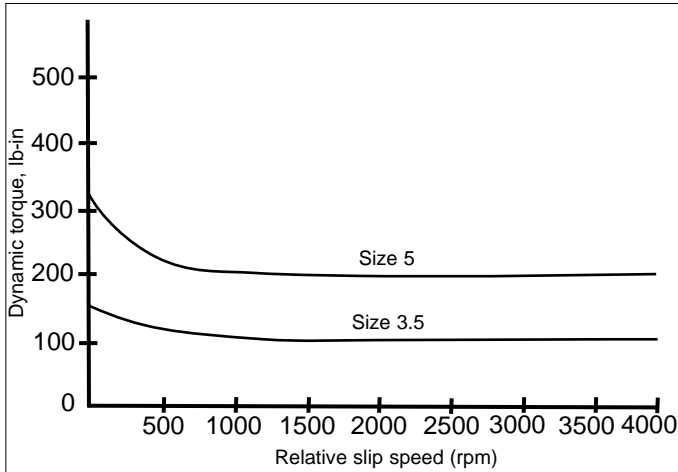

Figure 8-1: Dynamic torque curve for size 3.5 and 5 CCC, CRP, CRS and BFM

**Relationship between magnetism and torque buildup**

When an electrical current is applied to a coil in a magnet body, a magnetic force is developed. As the force develops, and the armature pulls into contact with the friction face of the drive hub, torque begins to build up. This buildup of torque is a fixed ratio of rate of magnetism buildup and is called the engagement curve. At time 0, rated coil voltage is applied and current begins to build. As the current builds, the magnetic force increases. At time T1, the magnetic force is strong enough to pull in the armature and from that point transmitted torque begins to build. At time T3, 100% of the rated torque is available for starting or stopping a load. The importance of this relationship is that when an electrical signal is received by a clutch or brake, the load does *not* instantaneously start or stop. Therefore, the engagement and disengagement times must be factored into the application. This may seem like an inconsequential period of time (milliseconds), but if a customer has an application requiring extremely high cycle rates, or requires very accurate stopping distances, it becomes necessary to consider time even as small as milliseconds.

**Fundamental clutch and brake formula**

Clutch or brake selections may be determined by the relationship:

$$T = 5,252 \times hp \times SF$$

Where:

T = Average dynamic torque, lb-ft

hp = Motor horsepower

SF = Service Factor

N<sub>cb</sub> = rpm of the clutch/brake shaft

5,252 = Constant

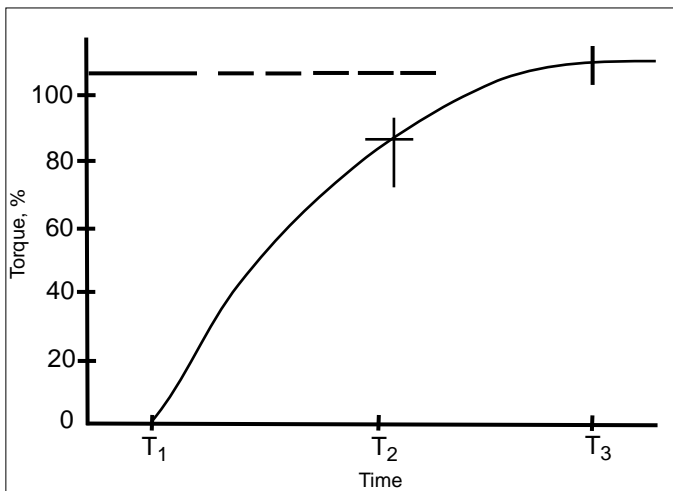

Figure 8-2

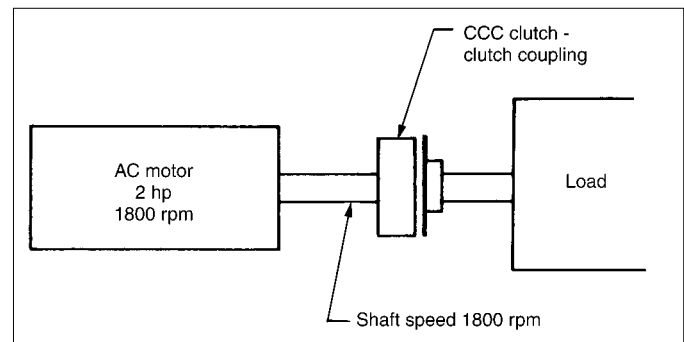

Figure 8-3: Case one application example

Note that this is the elementary torque formula we derived earlier while discussing work, horsepower, torque and speed. However, the concept of *service factor* has been added and the rpm in the formula is the rpm of the shaft on to which the clutch or brake will be mounted. This may not be the motor shaft rpm.

**Service factor**

## Multiplication of torque

In most applications described so far the clutch/brake has been located on the motor or high speed shaft. It is extremely important, but often forgotten, to determine the effect of speed changes in a drive system. Since frictional losses in a pulley system, sprocket system, or gear train incorporating a clutch/brake and operating at constant speed, is small and can be disregarded, the horsepower delivered by the clutch may equal the horsepower of the prime mover. When speed is reduced or increased within the drive system, the *horsepower* delivered by the motor, will remain constant. However, the *torque* required to be transmitted by any given secondary shaft, will change. As a result, the clutch/brake size required may also change. The following examples illustrate this point:

CASE TWO: Given — A 1 hp, 1800 rpm NEMA B motor. Select the proper size unit CCC clutch – clutch coupling.

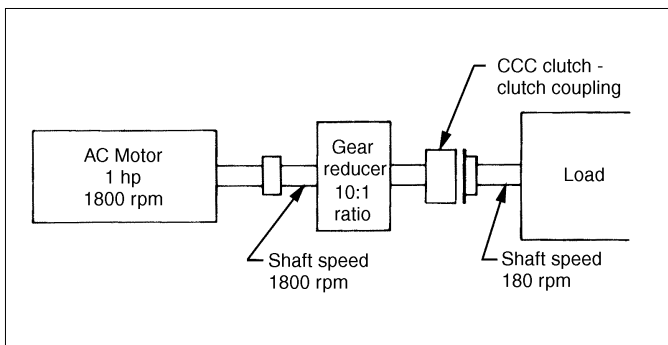

Figure 8-4: Case two application example

$$T = \frac{5,252 \times \text{hp} \times \text{SF}}{N}$$

Use grid work sheet in back of book.

CASE THREE: Given — A 1 hp, 3600 rpm NEMA B motor. Decide what size clutch is to be used and which location should be selected.

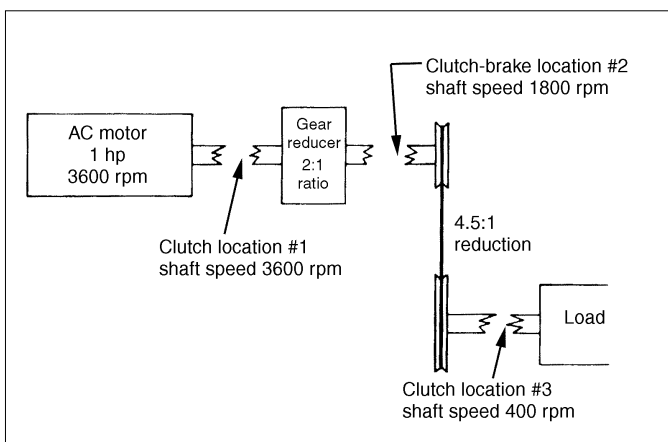

Figure 8-5: Case three application example

Use grid work sheet in back of book for each location. Which location would be best? Did you pick a size 5 (CCC-50) product for location number 2? Why?

Inertia can be defined as the tendency of a body at rest to remain at rest; if in motion to remain in motion. Since clutches and brakes are used to start, or to stop motion, their application must take into account the inertia of the load that is being started or stopped. Therefore, it is necessary to quantify how much energy it will take to start or stop the load. For example, when starting or stopping a flywheel, you must overcome its inertia. This concept of inertia is particularly important when an application involves time or when cycle rates are high enough to make heat calculations necessary. It is also required in order to calculate dynamic torque which was mentioned earlier and will be explained in detail in a later section.

In most applications people don't know what the inertia of their application is, so we have to be able to recognize and find the critical physical properties from which inertia is calculated. In simple terms, as defined earlier, inertia is the product of the weight of an object ( $W$ ) and the square of its radius of gyration ( $K^2$ ). It is usually represented by the expression  $WK^2$ , and can be expressed in "pound feet squared" ( $\text{lb-ft}^2$ ).

The value of  $WK^2$  can be called the flywheel effect and is indicative of the moment of inertia. For instance, if we were to determine the inertia of a wheel that weights 350 lbs, and is 6 ft in diameter, the solution would be:

$$WK^2 = \frac{1}{2} wt r^2$$

Where:  $r = \text{dia.}$

$$WK^2 = \frac{1}{2} \times 350 \text{ lbs} \times (\frac{6}{2} \text{ ft})^2$$

$$WK^2 = 1,575 \text{ lb-ft}^2$$

Weight is distributed uniformly throughout a rotating body. In other words, the wheel acts as though its weight were concentrated not at the rim but at some smaller radius  $K$  called radius of gyration. The radius of gyration  $K$  is equal to  $0.707 R$  for a disc or cylinder. Values of  $K^2$  for several other shapes of rotating bodies are given in the appendix.

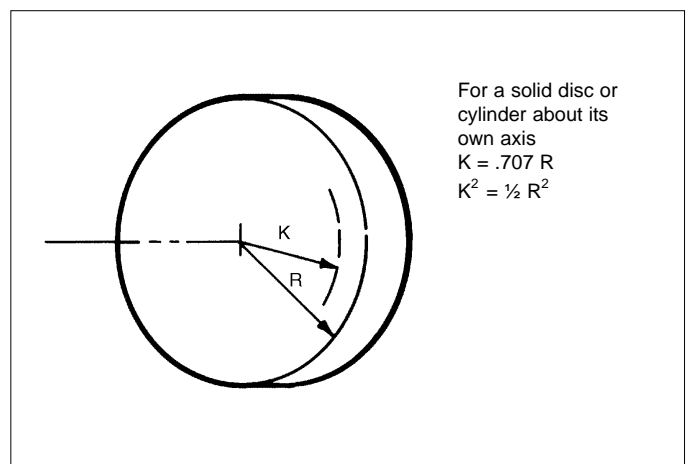

Figure 8-6

## Inertia

As a point of information, the terminology for this inertia is moment of inertia and is differentiated from *mass moment of inertia* which is a term you may encounter in applications where metric measures are in use. Polar mass moment of inertia is represented by "J<sub>m</sub>" and can be expressed as oz-in/sec<sup>2</sup>. It is used because it closely approximates the metric measurement of inertia. We mention this here because you may hear engineers use it or you may see it as part of an inquiry. Be aware that it does exist and know that for our purpose the important concept is inertia and the components that make it up, i.e., weight and distance.

### Calculation of Wk<sup>2</sup>

In most practical applications, the weight of all of the mechanical components is rarely known or given. Therefore, calculation of inertia can become difficult. However, there are some approximations and shortcuts which can simplify the calculations.

To determine the Wk<sup>2</sup> of a steel part, the appendix includes a chart with the calculated Wk<sup>2</sup> for solid steel shafting and discs from 1/8" to 102" diameter. Note that this table gives Wk<sup>2</sup> per inch of length and must be multiplied by the total length in inches of the shafting or disc in question in order to get the total Wk<sup>2</sup>. For instance, a piece of 1 1/2" diameter ( ) shafting 30" long would be calculated as follows:

Wk<sup>2</sup> for 1 1/2" = .0010 lb-ft<sup>2</sup> (see Figure 8-7)

$$Wk^2 = 30 \times .0010 \text{ lb-ft}^2 = .03 \text{ lb-ft}^2$$

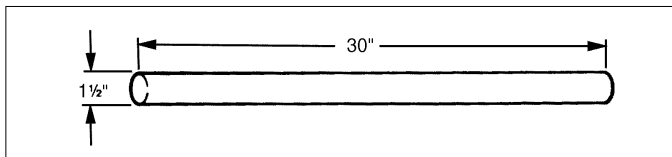

Figure 8-7

The technique of calculating inertia by breaking up a relatively complex part into its component geometric shapes, calculating inertia of those relatively simple parts and totalling those figures, is widely used. Inertias for basic power transmission parts are generally available from the manufacturers, however the Wk<sup>2</sup> can be calculated if the manufacturer's figures are not available.

Example: Calculate the inertia of the following coupling:

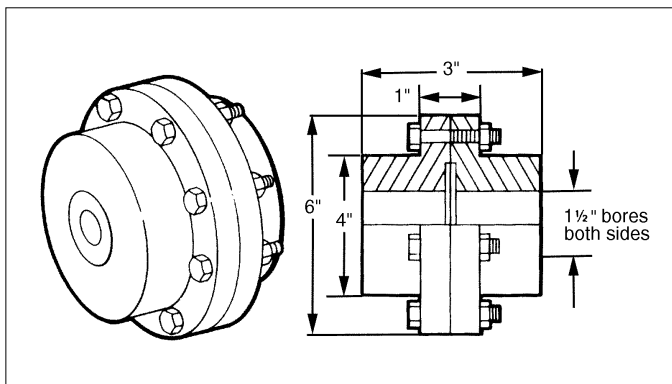

Figure 8-8

There are several ways of solving this problem. The following is only one method which illustrates calculations of Wk<sup>2</sup> via its component shapes:

Find the Wk<sup>2</sup> of the 4" diameter 2" thick part and the Wk<sup>2</sup> of the 6" in diameter 1" thick part.

From the Wk<sup>2</sup> chart in the appendix:

$$4" \text{ diameter is } .0491 \text{ per inch times } 2" = .0983 \text{ lb-ft}^2$$

$$6" \text{ diameter is } .2488 \text{ per inch times } 1" = .2488 \text{ lb-ft}^2$$

$$\text{Subtotal } .3471 \text{ lb-ft}^2$$

Subtract the hole through the coupling.

$$1\frac{1}{2} \text{ diameter is } .0010 \text{ per inch times } 3" = .003 \text{ lb-ft}^2$$

$$.3471 \text{ lb-ft}^2$$

$$\text{Subtract } .0030 \text{ lb-ft}^2$$

$$\text{Final TOTAL} = .3441 \text{ lb-ft}^2$$

Another popular power transmission component commonly used is the sprocket. Calculate the Wk<sup>2</sup> of the two sprockets shown in Figure 8-9. Note: Ignore the hole bored through center of sprockets, and the teeth.

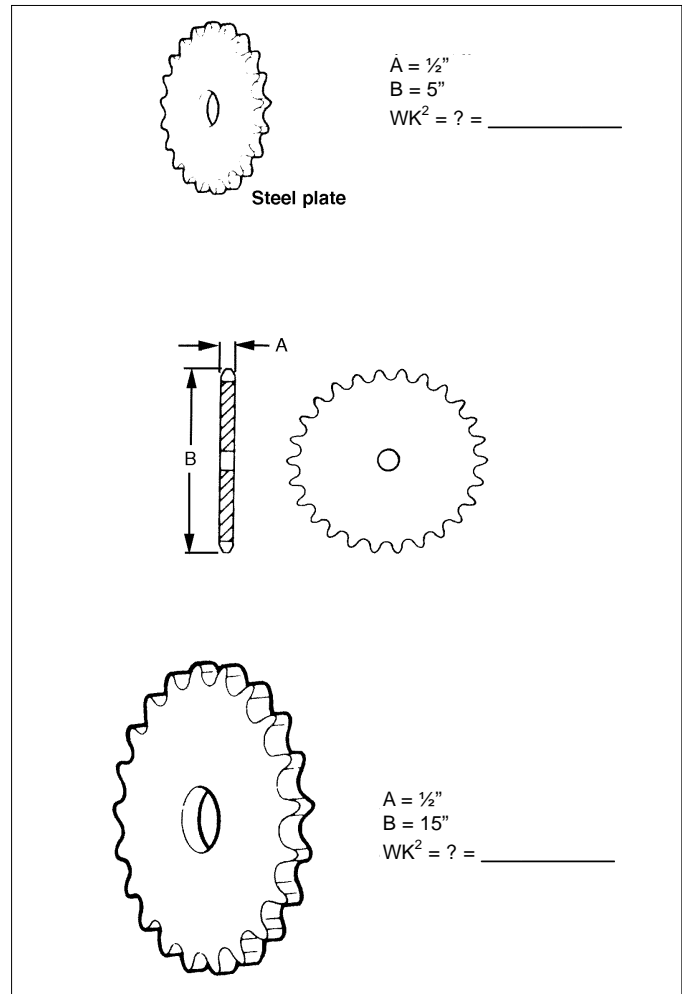

Figure 8-9

Likewise, most power transmission components can be broken down into simple discs and hollow cylinders in order to calculate their inertia. For instance, to determine

the inertia of a conveyer head pulley, this pulley can be broken down into its component parts.

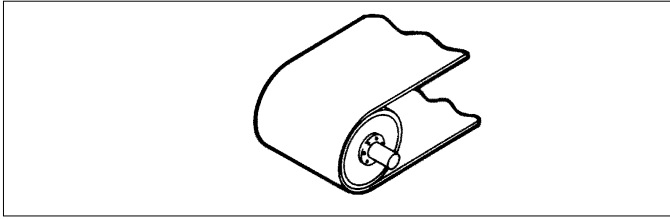

Figure 8-10

In this case there is a hollow cylinder, two end caps and a piece of shafting.

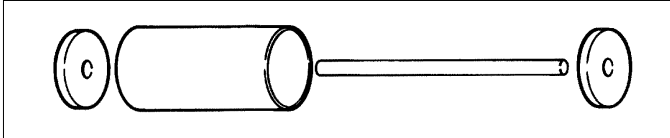

Figure 8-11

The inertia of each component can be determined, and add them together to obtain the complete inertia of the head pulley.

The inertia of the hollow cylinder can be determined by first calculating its inertia as if it were a solid piece of steel 15" in diameter and 20" long.

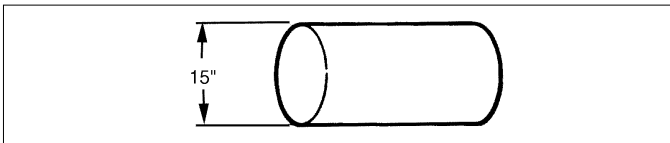

Figure 8-12

From the  $Wk^2$  chart in the appendix we find that a 14" diameter steel bar has the same  $Wk^2$  as a cylinder equal to the inside diameter of the hollow cylinder.

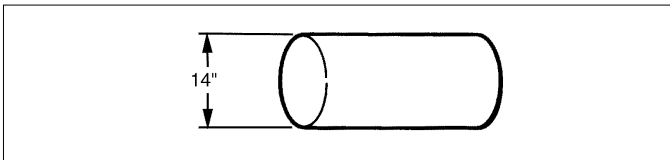

Figure 8-13

By subtracting the smaller  $Wk^2$  from the larger, one can arrive at the  $Wk^2$  of the hollow cylinder.

$$\text{O.D.} = 9.720 \text{ lb-ft}^2 \times 20" = 194.4 \text{ lb-ft}^2$$

$$\text{Minus I.D.} = 7.376 \text{ lb-ft}^2 \times 20" = 147.52 \text{ lb-ft}^2$$

$$\text{TOTAL cylinder } Wk^2 = 46.88 \text{ lb-ft}^2$$

The inertia of the end caps can be determined by using the  $Wk^2$  chart. From our chart, the  $Wk^2$  for a 14" diameter and 1" thick end cap is 7.376 lb-ft<sup>2</sup> each, 2 caps = 14.752 lb-ft<sup>2</sup>.

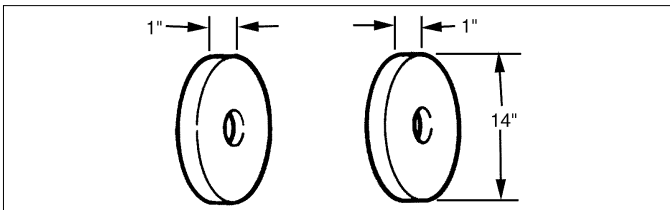

Figure 8-14

The shafting is also relatively simple to determine. It is 1½" in diameter and 30" long. Therefore:

$$Wk^2 = .0010 \text{ lb-ft}^2 \times 30 = .03 \text{ lb-ft}^2$$

Therefore, since the total inertia of the conveyer head pulley is the sum of the individual components  $Wk^2$ , the total  $Wk^2$  is:

$$1) \text{ Hollow cylinder} = 46.88 \text{ lb-ft}^2$$

$$2) \text{ End caps} = 14.752 \text{ lb-ft}^2$$

$$3) \text{ Shafting} = .03 \text{ lb-ft}^2$$

Total  $Wk^2$  of

$$\text{head pulley} = 61.662 \text{ lb-ft}^2$$

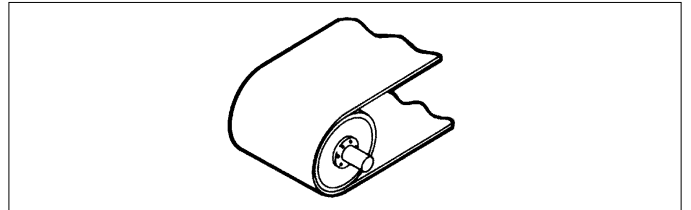

Figure 8-15

## Reflected inertia

In any power transmission system, the various moving components such as a conveyor belt, drums, sprockets, shafts, couplings, reducers, etc., do not necessarily operate at the same speed. Consequently, it is necessary to calculate the inertia as it is reflected to the clutch or brake. Inertia that is reflected from one shaft speed to a clutch/brake can be of two forms; linear or rotational.

### Reflected inertia - linear

The formula for calculating the reflected inertia of a component in linear motion where there exists a fixed speed relationship between the linear and rotating components is:

$$Wk^2 = W \left( \frac{V}{2\pi N_{cb}} \right)^2$$

Where:

W = The weight of the component

V = The velocity of the component in feet per minute

$N_{cb}$  = The rpm of the clutch/brake shaft

Example: Calculate the inertia of the weight on a conveyer as it will be reflected to the clutch-brake.

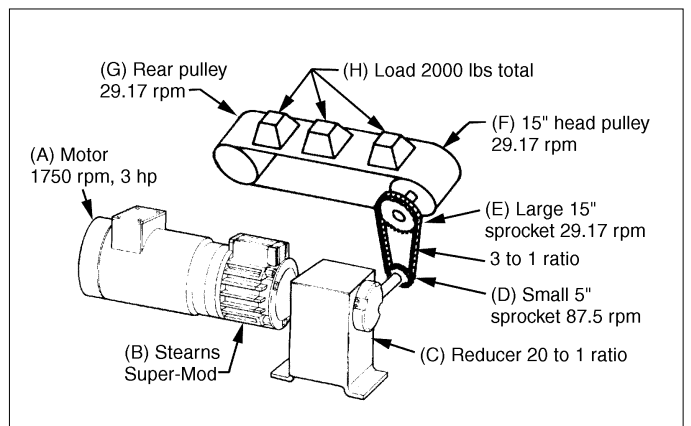

Figure 8-16



First calculate the velocity of the conveyer since it is one of the components of our formula.

Where:

$$\pi = 3.142$$

D = Diameter of head pulley

N = rpm

$$V = \pi DN$$

$$V = 3.142 \times 15/12 \text{ ft} \times 29.17 \text{ rpm}$$

$$V = 114.57 \text{ ft per minute}$$

Therefore:

$$Wk^2 = W \left( \frac{V}{2\pi N_{cb}} \right)^2$$

$$Wk^2 = 2,000 \left( \frac{114.57}{2\pi \times 1,750} \right)^2$$

$$Wk^2 = .217 \text{ lb-ft}^2$$

The reflected inertia that a clutch or brake would see from the load in this application would be .217 lb-ft<sup>2</sup>. Note that this is only the load inertia. In order to calculate the total inertia seen by the clutch or brake, one must also know the inertia of the conveyer sprockets and reducer.

### Reflected inertia - rotational

In some applications one may not have to be concerned with linear movement, but may have rotational movement; as in the case of a sprocket. In this case, one must consider the inertia of the rotational load. The formula for calculating the reflected inertia of a rotating component is:

$$Wk_f^2 = Wk_c^2 \times \left( \frac{N}{N_{cb}} \right)^2$$

Where:

$Wk_f^2$  = Inertia reflected to the clutch or brake

$Wk_c^2$  = Inertia of the component

N = rpm of the component

$N_{cb}$  = rpm of the clutch or brake shaft

Example: Determine the reflected inertia seen by a clutch-brake from the rotating sprocket, Part D in our conveyer example.

$Wk_c^2 = .060$  from your previous calculations

N = 87.5 rpm

$N_{cb} = 1,750$

find  $Wk_f^2$

Sprocket D

$$Wk_f^2 = Wk_c^2 \left( \frac{N}{N_{cb}} \right)^2$$

$$Wk_f^2 = .060 \left( \frac{87.5}{1,750} \right)^2$$

$$Wk_f^2 = .00015 \text{ lb-ft}^2$$

### Reflected inertia - total

If there are multiple secondary shafts rotating at different speeds, the total reflected inertia seen by the clutch/brake shaft is the sum of the reflected inertias plus the inertia of the CB. This is represented by the following formula:

$$Wk_i^2 = Wk_1^2 \left( \frac{N_1}{N_{cb}} \right)^2 + Wk_2^2 \left( \frac{N_2}{N_{cb}} \right)^2 + Wk_3^2$$

$$\left( \frac{N_3}{N_{cb}} \right)^2 + Wk_n^2 \left( \frac{N_n}{N_{cb}} \right)^2 + Wk_{cb}^2$$

In this example, the clutch/brake will see a total inertia that is made up of seven parts; reflected inertia from the linear component Part H; reflected rotational inertia from the low speed shaft Parts E, F, G; reflected rotational inertia from the intermediate speed shaft Part D; reflected rotational inertia from the reducer Part C; and the inertia of the clutch/brake Part B. First determine the  $Wk^2$  of each of those elements. Their summation is the total inertia that the clutch/brake will be asked to control.

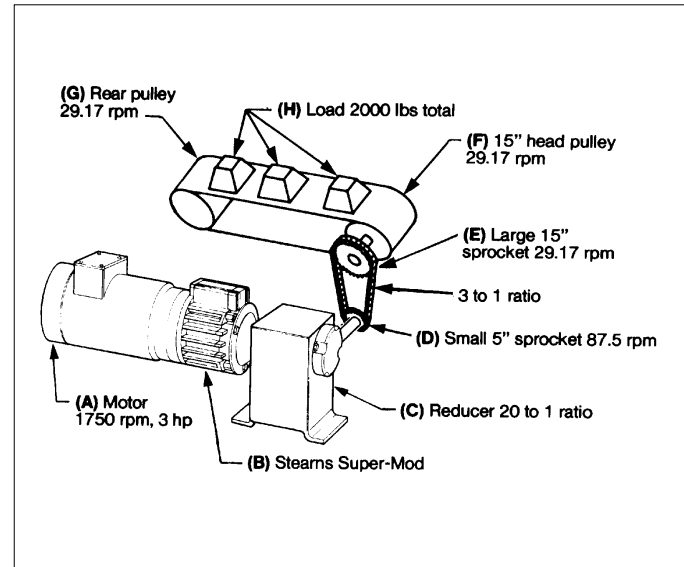

Figure 8-17

Using our conveyer example, four steps can be used to illustrate the calculation of linear, rotational, and total reflected inertia.

#### STEP ONE:

The linear inertia reflected to the clutch/brake from Part H was calculated earlier and found to be:

$$Wk^2 = W \left( \frac{V}{2\pi N_{cb}} \right)^2$$

$$Wk^2 = 2,000 \left( \frac{114.57}{2\pi \times 1,750} \right)^2$$

$$Wk^2 = .217 \text{ lb-ft}^2$$

#### STEP TWO:

The rotational inertia of the *low speed* shaft components Parts E, F, G reflected to the clutch/brake shaft is determined by totaling the inertia of the individual components:

$$\text{Part E - 15" large sprocket} = 4.86 \text{ lb-ft}^2$$

$$\text{Part F - head pulley} = 61.662 \text{ lb-ft}^2$$

$$\text{Part G - rear pulley} = 61.662 \text{ lb-ft}^2$$

$$\text{TOTAL low speed components} = 128.184 \text{ lb-ft}^2$$

The rotational inertia is then calculated as it will be reflected back to the brake shaft using the following formula:

$$Wk_f^2 = Wk_c^2 \left( \frac{N}{N_{cb}} \right)^2$$

$$Wk = 128.184 (.016668)^2$$

$$Wk_f^2 = .0356 \text{ lb-ft}^2 \text{ or } .036 \text{ lb-ft}^2 \text{ rounding off}$$

Therefore, the rotational inertia from Parts E, F and G, which will be reflected back to the clutch-brake, is .036 lb-ft<sup>2</sup>.

**STEP THREE:**

The rotational inertia of the *intermediate speed* shaft component, Part D, reflected to the higher speed clutch-brake shaft is: (as shown before)

Sprocket D

$$Wk_c^2 = .060 \text{ lb-ft}^2$$

$$Wk_r^2 = Wk_c^2 \left( \frac{N}{N_{cb}} \right)^2$$

$$Wk_r^2 = .060 \left( \frac{87.5}{1,750} \right)^2$$

$$Wk_r^2 = .00015 \text{ lb-ft}^2$$

This is an exceedingly small value and can be ignored for all practical purposes. Call it zero.

**STEP FOUR:**

The components on the *high speed* shaft that are of concern are the reducer and the brake side of the clutch/brake. In the above example, since no specific clutch/brake has been selected at this time it will not be added in that inertia for this example. However, this may be a significant figure, and should not be overlooked. The inertia of the reducer reflected to the high speed shaft from the reducer manufacturer is:

$$Wk^2 = .015 \text{ lb-ft}^2$$

The total inertia that will be reflected to the clutch/brake is the summation of the inertias that have been calculated.

Part C - Reducer	.015 lb-ft <sup>2</sup>
Part D - Intermediate speed shaft	.000 lb-ft <sup>2</sup>
Parts E, F, G - Low speed shaft	.036 lb-ft <sup>2</sup>
Part H - Linear components	.217 lb-ft <sup>2</sup>
TOTAL	<u>.268 lb-ft<sup>2</sup></u>

This is the inertia of the system (excluding the clutch/brake inertia) that the clutch/brake will be required to accelerate and decelerate. This total inertia is an important factor in determining the torque required to start or stop a moving load, the time required to start or stop a load, or the heat that a given clutch or brake must dissipate while starting or stopping a load.

**Dynamic torque**

Dynamic torque is defined as: "The torque required to start or stop a load when the drive and driven members of the unit are *not* rotating at the same speed." It is the actual torque required to overcome the inertia of a load. It is not connected with motor torque and can be calculated without regard to motor horsepower.

Dynamic torque for an inertia load must be calculated when selecting a clutch or brake that must accelerate or decelerate the load in a specific period of time or the actual starting or stopping time must be known. It is the basic formula to be used when an application is being determined based on the characteristics of the load.

To illustrate this type of calculation of dynamic torque, refer to the conveyer system for which we previously calculated the reflected inertia.

The required dynamic torque for this conveyer system can now be calculated, using the following formula:

$$T_d = \frac{Wk^2 \times N}{308t}$$

Where:

T<sub>d</sub> = Dynamic torque

Wk<sup>2</sup> = Total inertia seen by the clutch/brake

N = rpm of the clutch/brake

t = Stopping time in seconds (or starting time)

308 = Constant

Now the customer has requested a clutch/brake on the motor shaft that will stop their load in .4 seconds.

T<sub>d</sub> = Unknown, solve for dynamic torque

$$Wk^2 = .268$$

$$n = 1,750$$

$$t = .4$$

308 = Constant

$$T_d = \frac{Wk^2 \times N}{308t}$$

$$T_d = \frac{.268 \times 1,750}{308 \times .4}$$

$$T_d = 3.8 \text{ lb-ft}$$

The SM-210-1020, which has a nominal dynamic torque rating from the catalog of 44 lb-ft, is in excess of what is required to stop the load in the time specified. The catalog indicates that a size SM-100/180-1020 20 lb-ft has a dynamic torque rating at 1800 rpm of 20 lb-ft which is still larger than the dynamic torque calculated here.

We next could look at the SM-50-1020 with a dynamic torque of 10 lb-ft. This is sufficient for the required 4 lb-ft. Therefore, the recommendation would be for the SM-50 unit.

**Thermal capacity**

When a clutch or brake starts or stops a load, heat is generated. This heat comes principally from the friction of the working elements as they are pressed into contact with each other and come to a static condition after some slippage. This heat is absorbed by the various parts of the clutch or brake. The amount of heat that a clutch or brake can dissipate, depends upon the size of the parts that make up the unit and the materials they are made of. The ability of a particular clutch or brake to absorb and dissipate heat without exceeding certain temperature limitations, is known as thermal capacity.

The amount of heat energy created and dissipated by a clutch or brake is a function of the inertia of the load, the speed differential of the load, and the number of times the clutch/brake is to start or stop in a given period of time. Thermal capacity can be expressed in terms of *hp-sec per minute* and calculated by the following formula:

$$TC = \frac{Wk^2 \times N_{cb}^2 \times n}{3.22 \times 10^6}$$

Where:

TC = Thermal capacity, hp-sec/min

$Wk^2$  = Inertia seen by the clutch/brake including the clutch/brake inertia, lb-ft<sup>2</sup>

$N_{cb}$  = Speed differential between friction surfaces at the time of engagement, rpm

n = Number of starts/stops per minute. Note that this value can not be less than one (1) in this equation.

$3.22 \times 10^6$  = Constant

As any of the variables in this formula increase or decrease, the thermal capacity will respond likewise.

Using the above formula, determine the thermal capacity required in our conveyer example with 35 starts/stops per minute.

Thermal capacity using a size SM-50-1020:

TC = Unknown, solve for thermal capacity

$$Wk^2 = .268$$

$$N_{cb} = 1,750$$

$$n = 35$$

Therefore:

$$TC = \frac{.268 \times (1,750)^2 \times 35}{3.22 \times 10^6}$$

$$TC = 8.92 \text{ hp-sec/min}$$

Now compare this figure with the thermal capacity rating of the SM-50-1020 from the catalog. You will find its thermal capacity is 9 hp-sec/min. Therefore the SM-50-1020 checks out as sufficient for the thermal capacity requirement.

## 9. Summary

The application and selection of DC clutches and brakes is a combination of engineering formulas and approximations. As important as the understanding of these formulas are, you must also take into account the environmental conditions that the product will be subjected to throughout its lifetime. For example: A friction product should never be selected for use in hazardous atmospheres unless it has been designed, tested and approved for such use by an independent testing laboratory such as Underwriters Laboratories (UL) or Canadian Standards Association (CSA).

To better assist the customer in the selection process and application of DC clutches and brakes you need to watch out for unusual environment service conditions such as:

- Operation in wet or damp areas
- Operation speeds in excess of rated
- Exposure to gritty dust
- Poor ventilation
- Exposure to oil vapor
- Exposure to salty air
- Exposure to radioactivity
- Exposure to mechanical loads involving thrust or overhung in excess of rated
- Exposure to chemical fumes

Many times the customer assumes you know all about his or her specific application. It takes just a few extra minutes of time to ask questions regarding the operating environment and this time may be very well spent upfront rather than after troubles begin, because of an unusual operation condition.

Each application can be different and the concepts presented in this program are important in making the optimum product decision. The important points to remember are that electromagnetic DC clutches, brakes, and clutch-brake packages can be very versatile and accomplish many indexing, cycling, connect-disconnect, and positioning functions. Electromagnetic DC products like those manufactured by Stearns are most assuredly the more cost effective type for controlling the power flow in a mechanical power transmission system.

Additionally, Stearns has many years of effective use and experience with DC products since Stearns originally introduced this product line in 1928.

## 10. Typical Stearns DC Product Applications

### Material handling

- Conveyers
- Stackers
- Bucket elevators
- Cranes and hoists (gantry)
- Aviation baggage/freight conveyers
- Automated storage/retrieval systems
- Carousel machinery
- Gantry cranes
- Steel coil levelers
- Feeder machinery

### Packaging

- Stretch wrap machinery
- Palletizers
- Strapping machinery
- Carton - tape and seal machines
- Labeling equipment
- Bag and box making machines

### Printing/paper handling

- Business form presses
- Sheet fed presses
- Slitters and sheeters
- Laminator machines

### Machine tools

- Lathes
- Transfer line equipment
- Mill, drill and tap machinery
- Presses and brakes

### Textile machinery

- Warpings
- Carding machines
- Sewing equipment
- Knitting machines

### Food processing

- Bakery ovens
- Bottling machinery
- Meat saws and processing equipment
- Package and wrap equipment
- Vending machines
- Dough process equipment

### Steel mill and foundry equipment

- Rolling mill stands
- Transfer cars
- Drawbench machinery
- Cooling fans
- Push-pull carts
- Heat treat ovens

### Mining equipment

- Ore buckets and conveyers
- Ball mills
- Coal handling systems

### Special machinery

- Saw mill carriages and transfer equipment
- Concrete block and brick machines
- Fan drives
- Pump drives
- Laundry equipment
- Balancing machines
- Shoe manufacturing equipment
- Bowling pin setter machinery
- IC engine driven mobile equipment
- Communication and radar drives
- Plywood machinery
- Secure door systems
- Tire molding equipment
- Aviation ground support equipment and air-conditioning carts
- Miscellaneous military equipment

# 11. Appendix

## Application engineering formulas

### Basic torque formula:

$$T = \frac{hp \times 5,252}{N_{cb}} \times SF$$

Where:

T = Average dynamic torque, lb-ft

hp = Motor horsepower

SF = Service factor

$N_{cb}$  = rpm of the clutch/brake shaft

5,252 = Constant

### Inertia:

$$I = W \times K^2$$

Where:

W = Weight of the object

$K^2$  = The square of the radius of gyration

### Velocity, linear:

$$V = \frac{DN}{\pi}$$

Where:

$\pi$  = 3.142

D = Diameter of drive head pulley

N = rpm

### Reflected inertia - linear:

$$Wk_L^2 = W \left( \frac{V}{2\pi N_{cb}} \right)^2$$

Where:

W = The weight of the component, lb

V = The velocity of the component in feet per minute

$N_{cb}$  = The rpm of the clutch/brake shaft

### Reflected inertia - rotational:

$$Wk_r^2 = W_c \times \left( \frac{N}{N_{cb}} \right)^2$$

Where:

$Wk_r^2$  = Inertia reflected to the clutch or brake

$Wk_c^2$  = Inertia of the component

$N_c^2$  = rpm of the component

$N_{cb}$  = rpm of the clutch or brake shaft

### Dynamic torque:

$$T_d = \frac{Wk^2 \times N}{308t}$$

Where:

$T_d$  = Dynamic torque, lb-ft

$Wk^2$  = Total inertia seen by the clutch/brake (including the clutch/brake inertia and motor inertia if applicable), lb-ft<sup>2</sup>

N = rpm of the clutch/brake

t = Stopping time in seconds (or starting time)

308 = Constant

TC =

$$\text{Where: } \frac{Wk^2 \times N_{cb}^2 \times n}{3.22 \times 10^6}$$

TC = Thermal capacity, hp-sec/min

$Wk^2$  = Inertia seen by the clutch/brake including the clutch/brake inertia, lb-ft<sup>2</sup>

$N_{cb}$  = Speed differential between friction surfaces at the time of engagement, rpm

n = Number of starts/stops per minute. Note that this value can not be less than one (1) in this equation.

3.22 X 10<sup>6</sup> = Constant

### Thermal capacity:

## Wk<sup>2</sup> of Steel Shafting or Disc per Inch of Length or Thickness

Diameter (inch)	Wk <sup>2</sup> (lb-ft <sup>2</sup> )	Diameter (inch)	Wk <sup>2</sup> (lb-ft <sup>2</sup> )	Diameter (inch)	Wk <sup>2</sup> (lb-ft <sup>2</sup> )	Diameter (inch)	Wk <sup>2</sup> (lb-ft <sup>2</sup> )	Diameter (inch)	Wk <sup>2</sup> (lb-ft <sup>2</sup> )
1/8	4.53 X 10 <sup>-8</sup>	4	.0491	9 <sup>3</sup> / <sub>4</sub>	1.735	25	75.00	48	1019.2
1/4	7.47 X 10 <sup>-7</sup>	4 <sup>1</sup> / <sub>4</sub>	.0626	10	1.920	26	87.74	49	1106.8
3/8	3.83 X 10 <sup>-6</sup>	4 <sup>1</sup> / <sub>2</sub>	.0787	10 <sup>1</sup> / <sub>2</sub>	2.334	27	102.0	50	1200.0
1/2	1.21 X 10 <sup>-5</sup>	4 <sup>3</sup> / <sub>4</sub>	.0977	11	2.811	28	118.0	51	1298.9
5/8	2.93 X 10 <sup>-5</sup>	5	.1200	11 <sup>1</sup> / <sub>2</sub>	3.358	29	135.8	52	1403.8
3/4	6.07 X 10 <sup>-5</sup>	5 <sup>1</sup> / <sub>4</sub>	.1458	12	3.981	30	155.5	53	1514.9
7/8	.0001	5 <sup>1</sup> / <sub>2</sub>	.1757	12 <sup>1</sup> / <sub>2</sub>	4.687	31	177.3	54	1632.5
1	.0002	5 <sup>3</sup> / <sub>4</sub>	.2099	13	5.484	32	201.3	55	1756.9
1 <sup>1</sup> / <sub>8</sub>	.0003	6	.2488	13 <sup>1</sup> / <sub>2</sub>	6.377	33	227.7	56	1888.2
1 <sup>1</sup> / <sub>4</sub>	.0005	6 <sup>1</sup> / <sub>4</sub>	.2930	14	7.376	34	256.6	57	2026.7
1 <sup>3</sup> / <sub>8</sub>	.0007	6 <sup>1</sup> / <sub>2</sub>	.3427	14 <sup>1</sup> / <sub>2</sub>	8.487	35	288.1	58	2172.7
1 <sup>1</sup> / <sub>2</sub>	.0010	6 <sup>3</sup> / <sub>4</sub>	.3986	15	9.720	36	322.5	59	2326.5
1 <sup>5</sup> / <sub>8</sub>	.0013	7	.4610	15 <sup>1</sup> / <sub>2</sub>	11.08	37	359.8	60	2488.3
1 <sup>3</sup> / <sub>4</sub>	.0018	7 <sup>1</sup> / <sub>4</sub>	.5304	16	12.58	38	400.3	66	3643.1
1 <sup>7</sup> / <sub>8</sub>	.0024	7 <sup>1</sup> / <sub>2</sub>	.6075	16 <sup>1</sup> / <sub>2</sub>	14.23	39	444.2	72	5159.6
2	.0031	7 <sup>3</sup> / <sub>4</sub>	.6926	17	16.04	40	491.5	78	7166.7
2 <sup>1</sup> / <sub>4</sub>	.005	8	.7864	18	20.15	41	542.5	84	9558.9
2 <sup>1</sup> / <sub>2</sub>	.0075	8 <sup>1</sup> / <sub>4</sub>	.8894	19	25.02	42	597.4	90	12597
2 <sup>3</sup> / <sub>4</sub>	.0110	8 <sup>1</sup> / <sub>2</sub>	1.002	20	30.72	43	656.4	96	16307
3	.0156	8 <sup>3</sup> / <sub>4</sub>	1.125	21	37.34	44	719.6	102	20782
3 <sup>1</sup> / <sub>4</sub>	.0214	9	1.260	22	44.98	45	787.3		
3 <sup>1</sup> / <sub>2</sub>	.0288	9 <sup>1</sup> / <sub>4</sub>	1.405	23	53.73	46	859.6		
3 <sup>3</sup> / <sub>4</sub>	.0380	9 <sup>1</sup> / <sub>2</sub>	1.564	24	63.70	47	936.9		

To determine Wk<sup>2</sup> of a given shaft length or disc shape thickness, multiply the table value given above by the length, or thickness, in inches.

# Radius of Gyration, Squared

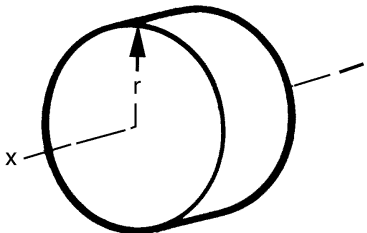
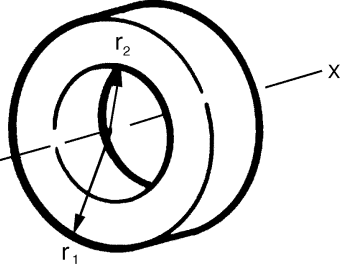
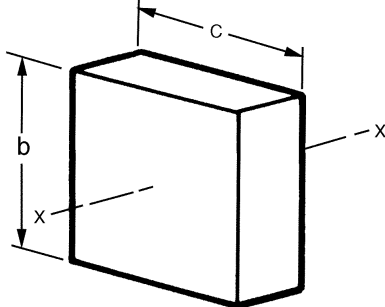
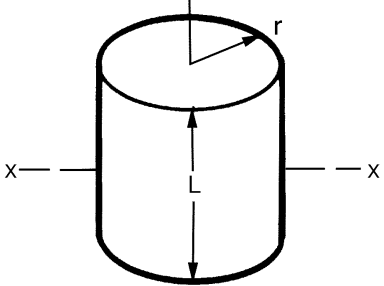
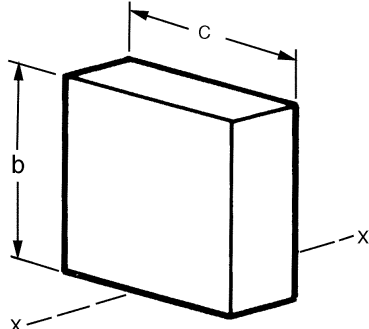
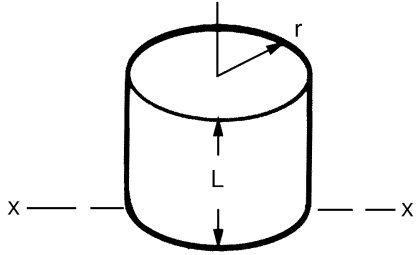
	<div style="border: 1px solid black; padding: 5px; width: fit-content; margin: 0 auto;"> <b>Cylinder about Its Own Axis</b>  <b>x-x</b> </div> <p>Solid</p> $K^2 = \frac{1}{2}r^2$		<p>Hollow</p> $K^2 = \frac{1}{2}(r_1^2 + r_2^2)$
	<div style="border: 1px solid black; padding: 5px; width: fit-content; margin: 0 auto;"> <b>Axis through Center</b>  <b>x-x</b> </div> <p>Prism</p> $K^2 = \frac{1}{12}(b^2 + c^2)$		<p>Cylinder</p> $K^2 = \frac{L + 3r^2}{12}$
	<p>Prism</p> $K^2 = \frac{1}{12}(4b^2 + c^2)$		<p>Cylinder</p> $K^2 = \frac{4L^2 + 3r^2}{12}$



## 12. Other Products

In addition to electrically engaged industrial clutches and brakes, Stearns Division manufactures and sells:

### **SINPAC® switches**

Stearns SINPAC switches represent a revolutionary approach to starting split phase, capacitor start, and capacitor start/capacitor run single-phase induction motors. Reliable solid-state circuitry replaces mechanical centrifugal switch, and actuator.

### **AAB brakes**

AAB brakes are spring set and electrically released. This type of brake develops braking and holding torque in the absence of electrical power.

When electrical power is applied, the armature plate is pulled against the magnet body and the force of the pressure spring by electromagnetic forces. This action releases the friction disc, thereby allowing free rotation of the brake hub and connected shaft. With removal of the electrical power, the electromagnetic force is removed (turned-off), and the pressure spring will move the armature plate to clamp the friction disc between the pressure plate and the armature. Braking and holding torque is developed by this clamping action and the brake hub transmits the torque to the shaft.

AAB brakes are available to meet a wide range of product requirements. They incorporate asbestos free friction disc materials and the friction discs are easily replaceable. A shortened or recessed hub is available for face mounting or to provide for maximum space efficiency. An optional manual release lever is available to allow shaft rotation under no power or emergency conditions. Customer designs and modifications are possible...consult the factory.

### **Heavy duty electric clutches and brakes**

The heavy duty line of clutches and brakes are multiple disc, direct acting, DC actuated units. There are three basic products: The Style E electrically engaged clutch, the SCE spring-engaged, electrically-released clutch, and the SCEB spring-engaged, electrically-released brakes. The primary markets for these clutches are rolling mills, rotary kilns, rod and ball mills, crushers, pump drives, and emergency standby power systems.

#### **Style E electrically engaged clutch**

Style E clutches are available in three configurations. The basic Style E offers the most economical means of providing heavy duty clutching. Style E clutches offer these features:

- Torque ratings from 140 lb-ft to 9000 lb-ft
- Collector rings can be mounted on the drive hub for minimum diametrical clearance or on the magnet body to minimize overall length

The Style E, Class S series is available with torque ratings from 600 lb-ft to 9000 lb-ft. Style E, Class S clutches offer several features that simplify serviceability:

- Two-piece collector ring assembly allows replacement without disassembling clutch

- Detachable drive hub allows replacement of friction discs without disturbing equipment on either side of clutch

The Style E, Class M series provides torque capabilities from 3000 lb-ft to 60,000 lb-ft. Style E, Class M clutches offers these design features:

- Pilot bearing helps correct for minor shaft misalignment
- Detachable drive and driven hubs allow replacement of friction discs without disturbing equipment on either side of clutch
- Two piece collector ring assembly allows replacement without disassembling clutch

#### **Style SCE spring-engaged electrically-released clutch**

SCE clutches are spring engaged. Thus they require no power for engaging. Power is only applied to disengage the clutch.

The great force of the engagement springs in the SCE clutch provides high torque in a relatively compact package. The special bronze friction disc cage also permits much higher operating speeds than are available from cast iron cage clutches with equivalent torque ratings. The SCE is available with torque ratings from 450 lb-ft through 10,000 lb-ft. All SCE clutches offer these other design features:

- Two piece collector ring assembly allows replacement without disassembling clutch
- Detachable drive hub allows replacement of friction disc without disturbing equipment on either side of clutch.
- Manual release screws provided for disengagement in emergencies and for servicing

#### **Style SCEB spring-engaged, electrically-released brake**

Stearns SCEB brakes provide higher holding torque per package size than most other comparable spring set brakes. The unique friction disc pack used in these brakes also allows higher operating speeds per torque rating. The low inertia design means that the full brake capacity can be used to stop the load, not the rotating parts of the brake.

Stearns SCEB brakes require only simple electrical connections. There is no need for the expensive power supplies, plumbing connections, and control valves used for pneumatic or hydraulic type brakes. All SCEB brakes offer these additional design features.

- Detachable magnet body allows replacement of friction discs without disturbing equipment connected to brake
- Manual release screws provided for disengagement in emergencies and for servicing
- Integral conduit box for safe, simple wiring connections

#### **Stearns solenoid-actuated brakes**

Stearns offers several types of spring engaged disc brakes and are available for:

- Industrial duty
- Hazardous location
- Marine duty
- Navy
- Maritime duty

#### **Industrial duty brakes**

There are two types of enclosures available for industrial brakes.

- Standard enclosures - NEMA 1 and NEMA 2
- Dust-tight, waterproof (DTWP) enclosures - NEMA 4 and NEMA 4X

Brakes with *standard* enclosures are used in locations where NEMA Type 1 and 2 enclosures are required. When mounted on a NEMA C-face motor, a brake with a standard enclosure is drip-proof.

Brakes with NEMA 2 enclosures provide protection against:

- Accidental contact with the enclosed electrical connections and moving components of the brake
- Falling dirt
- Falling liquids and light splashing
- Dust, lint, fibers and flyings

Industrial brakes with NEMA 4 enclosures are used in locations where NEMA Type 3 and 4 enclosures are required. When mounted on a NEMA C-face motor that is enclosed, such as totally enclosed, non-ventilated (TENV) motor, the brake is dust-tight, waterproof. They are selected for outdoor installations, or where there are moist, abrasive or dusty environments.

Brakes with NEMA 4 enclosures provide protection against:

- Accidental contact with the enclosed electrical connections and moving components of the brake
- Falling dirt
- Falling liquids and light splashing
- Lint, fibers and flyings
- Windblown dust
- Rain, snow and sleet
- Low pressure hosedown and splashing water

Brakes with Nema 4X enclosures provide the same protection as the Nema 4 brakes, but also include: corrosion resistance, BISSC certification, meets National AAA Dairy Standards, compliance with Wisconsin Food and Dairy regulations. NEMA 4X brakes are suitable for washdown applications.

### **Hazardous location brakes**

Certain installations where explosive gases or ignitable dust are present in the atmosphere, require the use of Stearns hazardous location brakes. The hazardous locations are defined in the National Electrical Code (NEC). For a detailed discussion of these, refer to Bulletin 200.

The two major differences between Stearns hazardous location brakes and industrial brakes are:

- Enclosure design
- Thermal considerations

The enclosure of a hazardous location brake is designed to prevent flame propagation from inside the brake to the outside atmosphere. This is accomplished through tortuous flame paths having controlled clearances.

NOTE: Hazardous location brakes are not waterproof, and protection from weather and washdowns must be provided. Generally, compliance with the NEC is demonstrated by UL Listing of the hazardous location classifications product in

Underwriters Laboratories Location Equipment Directory. A label displaying the UL mark and required rating information will be found on each Stearns brake to confirm the listing. The Canadian Standards Association (CSA) monogram will be found on Stearns hazardous location brakes sold in Canada to confirm certification.

Stearns motor-mounted, hazardous-location electric disc brakes are Listed only when mounted to a listed hazardous-location motor of the same Class and Group at a UL approved motor manufacturer's facility, and where the combination has been accepted by UL or CSA. This procedure completes the explosion-proof assembly of the brake. However, foot-mounted Listed hazardous-location disc brakes are also available for coupling to a motor, and may be installed by anyone.

### **Marine duty brakes**

Stearns marine duty brakes are available from 10 through 1,000 lb-ft. All feature Stearns exclusive self-adjusting mechanism that ends the need for periodic brake adjustment.

A Stearns marine duty brake has a NEMA 4 enclosure (cast iron) with the following special features:

- Brass pressure plate
- Brass stationary discs
- Splined stainless steel hub
- Special friction discs
- (Optional) special interior coatings or materials

With the exception of these special internal components, marine brakes have the same construction and features of the comparable industrial brake models. The brass internal components prevent corrosion from condensation that may occur. As added protection against condensation, a space heater is recommended on all marine duty brakes.

Stearns marine duty brakes are suitable for many applications, including capstan, mooring, topping, and vang winches aboard maritime vessels, dry dock winches, and offshore jackup oil rigs. Marine brakes are designed to conform with the brake specifications in IEEE Standard 45, "IEEE Recommended Practice for Electrical Installations on Shipboard."

### **Navy brakes**

All Stearns Navy brakes are designed in accordance with Military Specification MIL-B-16392C. With additional modifications, Stearns Navy brakes can also meet MIL-E-17807B. Many of these series are also listed on the Navy's Qualified Products List, indicating that they have been tested recently and approved by the Bureau of Ships. The following features are common to all Navy brakes:

- Spraytight or watertight enclosure (NEMA 4)
- Ductile iron exterior (housing and endplate)
- Brass or ductile iron internal parts (pressure plate and stationary disc)
- Brass or ductile iron support plate
- Brass or stainless steel hardware
- Special paint per Navy Specifications
- Dead-man release
- AC voltages only

Navy brakes are available with automatic self-adjust or manual adjust. A special explosion-proof (not UL listed) version is also available.

#### **Maritime duty brakes**

Stearns maritime duty brakes are designed for shipboard applications where compliance with a Navy Military Specification is not required. These brakes are suitable for U.S. Coast Guard applications and many shipboard conditions where "no cast iron" construction, is specified. They are designed to conform with the brake specifications in IEEE Standard 45, "IEEE Recommended Practice for Electrical Installations on Shipboard." The maritime brakes are similar to a Navy brake in construction, but do not have a dead-man release or special Navy paint, and are not designed or tested to meet the Navy Specification MIL-B-16392C. They have the same self-adjust mechanism and manual release as the comparable industrial brakes.

The brass and ductile iron construction of maritime brakes helps to prevent corrosion due to condensation that may occur in a shipboard environment. For additional protection against condensation, a space heater is recommended as a modification on all maritime brakes.

A hazardous location maritime duty brake is also available.